

Installation Manual



US Patent no. 8,166,965

RetroFire

Direct Vent Gas Fireplace
Insert
natural gas RF24JDN
propane gas RF24JDP

RF24JDN-CL with **AutoFire™**
(co-linear/natural gas)

RF24JDP-CL with **AutoFire™**
(co-linear/propane gas)

RF24JDN-CA (co-axial/natural gas)

RF24JDP-CA (co-axial/propane gas)

Installer: Leave this manual with the appliance.
Consumer: Retain this manual for future reference.

AutoFire™

Canadian Patent 2,717,779 Issued October 24 2017
US Patent 10,060,624 Issued August 28 2018
US Patent 10,935,246 Issued March 2 2021

Installer: Place model/serial number here.

⚠ WARNING:
FIRE OR EXPLOSION HAZARD
Failure to follow safety warnings
exactly could result in serious
injury, death, or property damage.

Do not store or use gasoline or other
flammable vapors and liquids in the
vicinity of this or any other appliance.

WHAT TO DO IF YOU SMELL GAS

- Do not try to light any appliance.

- Do not touch any electrical switch; do not use any phone in your building.
- Leave the building immediately.
- Immediately call your gas supplier from a neighbor's phone. Follow the gas supplier's instructions.
- If you cannot reach your gas supplier, call the fire department.

Installation and service must be performed by a qualified installer, service agency or the gas supplier.

⚠ DANGER



Hot glass
will cause burns.

Do not touch glass
until cooled.

Never allow children
to touch glass.

A barrier designed to reduce
the risk of burns from the hot
viewing glass is provided with this
appliance and must be installed for
the protection of children and
other at-risk individuals.

This appliance may be installed in an after-market permanently located, manufactured (mobile) home where not prohibited by local codes. This appliance is only for use with the type of gas indicated on the rating plate. This appliance is not convertible for use with other gases, unless a certified kit is used.

INSTALLER: Leave this manual with the appliance.
CONSUMER: Retain this manual for future reference.

Massachusetts:

The piping and final gas connection must be performed by a licensed plumber or gas fitter in the State of Massachusetts. Also, see Carbon Monoxide Detector requirements on page 42 in this manual.

⚠ WARNING

This product can expose you to chemicals including Benzene, which is known to the State of California to cause cancer and birth defects or other reproductive harm. For more information go to www.P65Warnings.ca.gov.

Note: Natural gas, in its original state, contains Benzene.

This appliance is a domestic room-heating appliance. It must not be used for any other purposes such as drying clothes, etc.

This appliance is suitable for installation in a bedroom or bed sitting room.

Ce guide est disponible en français sur demande.



We recommend a US Certified National Fireplace Institute (NFI) specialist install our gas hearth products.



The information contained in this manual is believed to be correct at the time of printing. Miles Industries Ltd. reserves the right to change or modify any information or specifications without notice. Miles Industries Ltd. grants no warranty, implied or stated, for the installation or maintenance of your heater, and assumes no responsibility for any consequential damage(s).

© Copyright Miles Industries Ltd., 2026. All rights reserved.
Designed and manufactured for Miles Industries Ltd.

Welcome to Valor®

This appliance has been professionally installed by:

Dealer Name: _____

Phone: _____

Please read this manual BEFORE installing and operating this appliance.

Fireplace Safety	4
Specifications	6
Kits & Accessories.....	8
Approved Venting Components	9
Co-Linear with RA24CL.....	10
Overview	10
Dimensions	12
Typical Vent Installation	13
Vent Termination	14
Co-Axial with RA24CA.....	16
Overview	16
Dimensions	18
Typical Vent Installation	19
Vent Termination	20
Co-Axial + Co-Linear.....	20
Vent Terminal Location.....	20
Preparation	21
Existing Fireplace Preparation.....	21
Before Installation.....	22
Installation	23
Window & Burner Removal.....	23
Install Vent Plate	24
Connect Venting—Co-Linear	25
Connect Venting—Co-Axial.....	26
Reassemble Appliance.....	27

Connect Gas Supply.....	29
Install Fuel Bed.....	30
Traditional Log Set MF28LSK.....	30
Driftwood Kit MF28DWK.....	32
Refit & Check Window.....	34
Install Battery Holder.....	35
Pair Remote Control	36
Check Burner Aeration	37
Barrier Screen/Window Cover/Vent Shield	38
Bottom Cover / Fret.....	39
Install Handset Holder	40
Wiring Diagram.....	41
Commonwealth of Massachusetts	42
Appendix A – Lighting Instructions Plate	43
Appendix B – Remote Control Operation	44
Appendix C – Spare Parts	48

Fireplace Safety

This manual contains very important information about the safe installation and operation of the fireplace. Read and understand all instructions carefully before installing and operating the fireplace. Failure to follow these instructions may result in possible fire hazard and will void the warranty.

Replacement manuals are available by contacting the Valor Customer Service at 1-800-468-2567, or by visiting valorfireplaces.com.

WARNING: Extremely Hot!

Heat and flammability

- Some parts of the fireplace are extremely hot, particularly the glass window. Use the barrier screen provided or a gate to reduce the risk of severe burns.
- The glass windows can exceed 500°F at full capacity.
- Always keep the appliance clear and free from combustible materials, gasoline, and other flammable vapors and liquids.
- Be aware of hot wall surfaces! The wall directly above the fireplace can get very hot when the fireplace heats. Although safe, it may reach temperatures in excess of 200°F (93°C) depending on choice of optional accessories. Do not touch!
- Be aware of hot shelf/hearth/floor surfaces! Any projections directly around the fireplace can get very hot when the fireplace heats. Although safe, they may reach temperatures in excess of 200°F (93°C) depending on their elevation. Be careful of touching these! Do not put objects on the hearth or shelf. Temperature of projection surfaces will be reduced when barrier screen is installed.
- Some materials or items, although safe, may discolor, shrink, warp, crack, peel, and so on because of the heat produced by the fireplace. Avoid placing candles, paintings, photos and other combustible objects sensitive to heat or furniture within 36 inches (0.9 m) around the fireplace.
- Solid wood flooring in front of the fireplace (if allowed) may shrink during the heating season due to heat.
- Due to high temperatures, the appliance should be located out of traffic areas and away from furniture and draperies.
- Clothing or other flammable material should not be placed on or near the appliance.

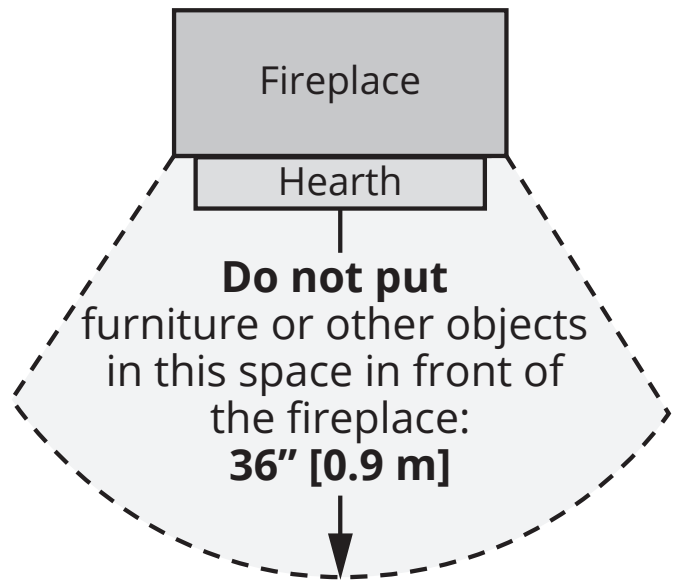

Barrier Screen and Safety

- A barrier designed to reduce the risk of burns from the hot viewing glass is provided with this appliance and must be installed for the protection of children and other at-risk individuals.
- Children and adults should be alerted to the hazards of high surface temperature and should stay away to avoid burns or clothing ignition.
- Young children should be carefully supervised when they are in the same room as the appliance. Toddlers, young children, and others may be susceptible to accidental contact burns. A physical barrier is recommended if there are at-risk individuals in the house. To restrict access to a fireplace or stove, install an adjustable safety gate to keep toddlers, young children, and other at-risk individuals out of the room and away from hot surfaces.
- Any safety screen, guard, or barrier removed for servicing an appliance, must be replaced prior to operating the appliance.

Fireplace Safety

Glass window



WARNING

Do not operate this appliance with the glass front removed, cracked, or broken.

Do not strike or slam the glass front.

Replacement of the glass front should be performed by a licensed or qualified service person.

- The glass front assembly must be in place and sealed before the unit can be placed into safe operation.
- The glass front assembly must only be replaced as a complete unit, as supplied by the fireplace manufacturer. No substitute material may be used.
- Do not use abrasive cleaners on the glass front assembly. Do not attempt to clean the glass when it is hot.

Venting

- This unit must be used with a vent system as described in this manual. No other vent system or components may be used.
- Never obstruct the flow of combustion and ventilation air. Keep the front of the appliance clear of all obstacles and materials for servicing and proper operation.
- This gas fireplace and vent assembly must be vented directly to the outside and must never be attached to a chimney serving a separate solid fuel burning appliance. Each gas appliance must use a separate vent system. Common vent systems are prohibited.

Intended use

- This appliance is designed and approved as a supplemental heater and provides the potential for most energy conservation when used while attended. The use of an alternate primary heat source is advisable.
- This unit is not for use with solid fuel.
- Do not use this heater as a temporary source of heat during construction.

Installation and Servicing

- Installation and repair should be done by a qualified service person. The appliance should be inspected before use and at least annually by a professional service person. More frequent cleaning might be required due to excessive lint from carpeting, bedding material, et cetera. It is imperative that control compartments, burners, and circulating air passageways of the appliance be kept clean.
- Do not use this appliance if any part has been under water. Immediately call a qualified service technician to inspect the appliance and to replace any part of the control system and any gas control that has been under water.

Specifications

This appliance is shipped without a vent plate. A vent plate is required for every installation. Either RA24CL—Co-linear vent plate (3" x 3") or RA24CA—Co-axial vent plate (5" x 3").

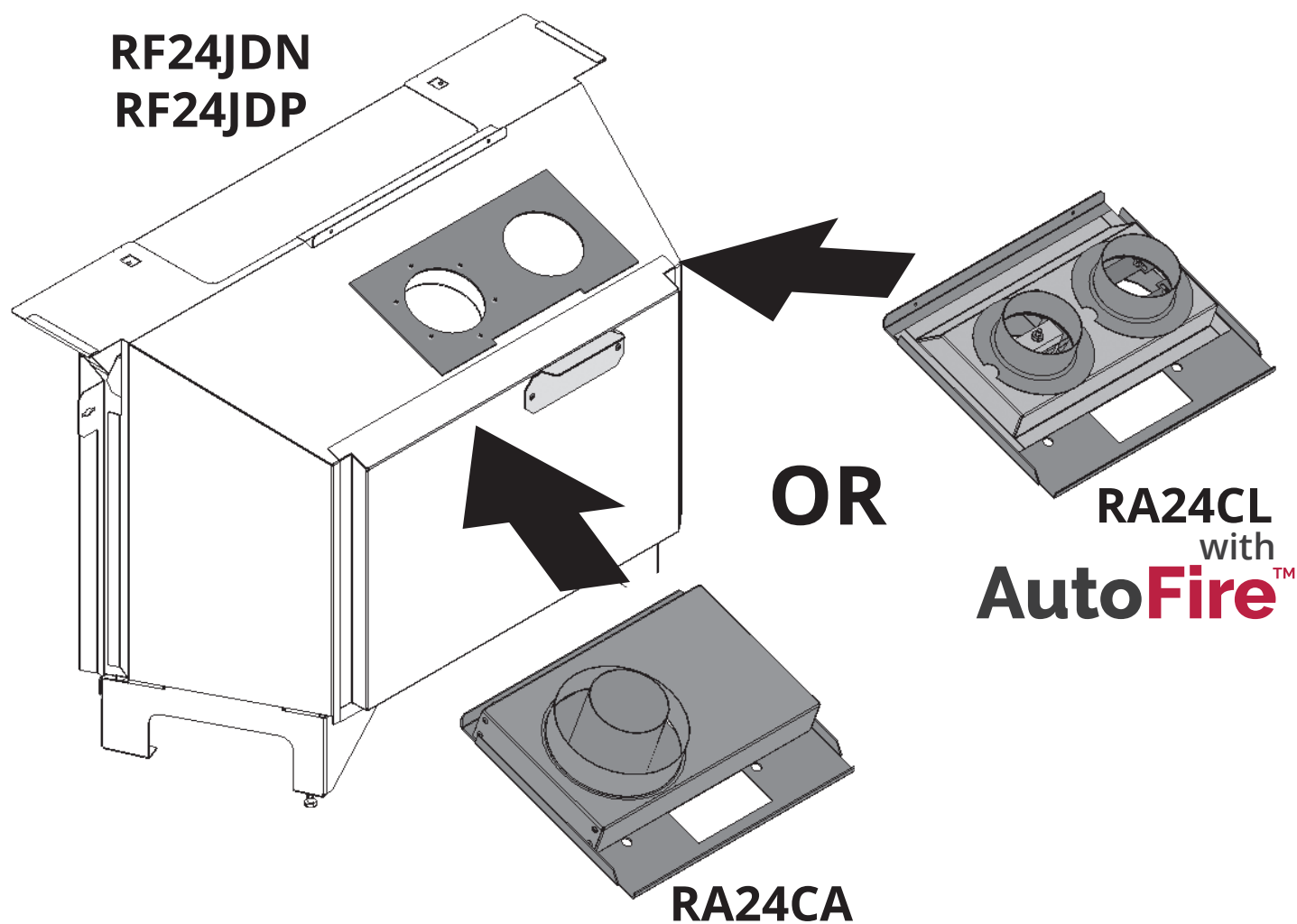

Specifications

Approval & Codes

This appliance is certified to ANSI Z21.88/CSA 2.33 American National Standard / CSA Standard for Vented Gas Fireplace Heaters for use in Canada and USA, and to CGA 2.17-91 High Altitude Standard in Canada. This appliance is for direct vent installations.

This appliance complies with CSA P.4.1-15 Testing method for measuring annual fireplace efficiencies.

The installation must conform to local codes or, in the absence of local codes, with the National Fuel Gas Code, ANSI Z223.1/NFPA 54 or the Natural Gas and Propane Installation Code CAN/CGA-B149.1. Only qualified licensed or trained personnel should install this appliance.

This appliance must be electrically grounded in accordance with local codes, or, in the absence of local codes, with the National Electrical Code, ANSI/NFPA 70 or the Canadian Electrical Code, CSA C22.1.

Ratings

Model	JDN-CA JDN-CL	JDP-CA JDP-CL
Gas	Natural	Propane
Altitude (Ft.)*	0-4,500 feet*	
Input Maximum (Btu/h)	20,000	18,000
Input Minimum (Btu/h)	6,500	12,500
Manifold Pressure (in w.c.)	3.2"	9.5"
Minimum Supply Pressure (in w.c.)	5"	11"
Maximum Supply Pressure (in w.c.)	10"	14"
Main Burner Injector Marking	82-580	92-200
Pilot Injector Marking	35	27
Min. Rate Bypass Screw	125	125

* Tested to CGA – 2.17-91 Gas fired appliances for use at high altitudes. In USA, installations may require deration over 2000'— Check local codes.

*High Altitude Installations

Input ratings are shown in BTU per hour and are certified without deration for elevations up to 4,500 feet (1,370 m) above sea level.

For elevations above 4,500 feet (1,370 m) in USA, installations must be in accordance with the current ANSI Z223.1 and/or local codes having jurisdiction. Heating value of gas in some areas is reduced to compensate for elevation—consult your local gas utility to confirm.

For installations at elevations above 4,500 feet (1,370 m) in Canada, please consult provincial and/or local authorities having jurisdiction.

Supply Gas

Heater engine RF24JDN uses natural gas.

Heater engine RF24JDP uses propane gas.

The supply pressure must be between the limits shown in the *Ratings* section.

The supply connection is a 3/8" NPT female connector. For detailed location, see *Dimensions* on page 12 or page 18.

Gas Conversion Kits

The RF24JD is supplied as natural gas or propane gas and is field convertible between fuels. See instructions packaged with the conversion kits for further details.

Electrical

The RF24JD does not require an electrical power source unless fitted with the optional 555CFK Circulating Fan Kit, in which case a grounded power source is required.

Floor/Hearth

This appliance is approved for installation into existing solid-fuel burning fireplaces only. Combustible material such as plywood and so on may be used for leveling and shimming beneath the unit. This appliance does not require a hearth other than to support the weight of certain fronts.

Non-Combustible Materials Specifications

Materials which will not ignite and burn. Such materials are those consisting entirely of steel, iron, brick, tile, concrete, slate, glass or plasters, or any combination thereof.

Materials that are reported as passing ASTM E 136, Standard Test Method for Behavior of Materials in a Vertical Tube Furnace at 750 °C shall be considered non-combustible materials.

Combustible Materials Specifications

Materials made of or surfaced with wood, compressed paper, plant fibers, plastics, or other material that can ignite and burn, whether flame proofed or not, or plastered or unplastered shall be considered combustible materials.

Outdoor Conversion Kit

The RF24JD models are supplied standard for indoor applications and may be adapted for installation in specific "outdoor" applications protected from weather as defined in the GV60CKO outdoor conversion kit manual.

Kits & Accessories

Required Kits

4006519	Barrier Screen
Vent Plates (choose one)	
RA24CA	Co-Axial Vent Plate for 5" x 3" co-axial venting
RA24CL	Co-Linear Vent Plate for 2 - 3" co-linear venting
Fuel Beds (choose one)	
MF28DWK	Driftwood Kit
MF28LSK	Traditional Log Set
Approved Venting Components	
See approved venting components list next page for co-axial and co-linear venting components.	
Note: When using the RA24CA Co-Axial Vent Plate, use the 590FVK2—5" x 3" Co-Axial Flex Vent and Terminal Adapter/Flashing	

Information accurate at the time of printing and subject to change without notice.

Optional Accessories



Decorative Cast Iron Frets	
RA24FK	Fret Kit, required for all frets
RA24TB	Traditional, Black Finish
1225VFB	Ventana Fret, Black
Gas Conversion Kits	
RA24JDNK	Conversion to natural gas
RA24JDPK	Conversion to propane gas
Other Accessories	
555CFK*	Circulating Fan Kit with 6' c/w grounded cord set*
1265WSK	Wall Switch Kit
RBWSK	Remote Battery & Wall Switch Kit
GV60CKO *	Outdoor Fireplace Conversion Kit
Hearth Gate	Hearth gates such as Cardinal's VersaGates are available at retail stores carrying safety products for children.



WARNING

*** NO ELECTRICAL CONNECTION ALLOWED for any outdoor installation!**

Approved Venting Components

Approved Direct Vent Suppliers for Valor Models RF24JD insert engine ONLY								
  Venting Parts Description		Venting Parts Code / availability by Manufacturer						
		DURA-VENT	SELKIRK	ICC EXCEL DIRECT	AMERIVENT	MILES INDUSTRIES	BDM	
Termination Caps	Vertical	Standard Co-axial	46DVA-VC	4DT-VT	—	4DVC 4DH-1313	— DVR6-VCH DVR6-VCSB	
		High Wind Co-axial	46DVA-VCH	—	TM-4SVT	—	—	
		Extended Co-axial	46DVA-VCE	—	—	—	—	
	Vertical	Co-linear	—	—	TM-IVT	HCL-99-33 HCL-913-33 HCL-1313-33	559CLT 940033B 940033HWS 940033RD	
			—	—	—	—	720SWK ²	—
Horizontal	—		—	—	—	—	—	
Vent Adapters / Couplers	Universal Adapter 3” Flex Coupler		2150	—	TM-CFAA3	—	95090390	
	Co-linear Flex Connector		46DVA-ADF	—	—	—	—	
	Co-linear-to-Co-axial Adapter		46DVA-GK 46DVA-CLTA	—	TM-4CTA	4DCAT33	—	
	Co-axial Adapter 5 x 3 to 6-5/8 x 4		—	—	—	—	590FVK2 (incl. flashing)	
Aluminum Flexible Liner	3” or 4” diameter		NOTE: 2-ply liner approved to CAN/ULC S635 suitable for venting gas appliances. As manufactured by Z-Flex, Flexmaster and others.					
	Co-Linear	2280 Series	AF3-35L	TM-ALK33	—	—	952703	
				TM-ALT33			952704	
Co-Axial 5” x 3”		—	—	—	—	590FVK2	—	
Flashings	Roof Flashing 0/12-6/12		46DVA-F6	4DT-AF6	TF-4FA	4DF (0/12-5/12)	—	DVR6-AF012
	Roof Flashing 7/12-12/12		46DVA-F12	4DT-AF12	TF-4FB	4DF12 (6/12-12/12)	—	DVR6-AF712
	Flat Roof Flashing		46DVA-FF	—	TF-4F	—	—	DVR6-TCF
	Masonry Flashing		—	—	TF-4MF	—	559FSK	—

- Notes:** 1. Follow instructions supplied with each manufacturer's components.
 2. In the Retrofire Series, the 720SWK Sidewall Kit can only be installed on the RF24JD insert engines models with RA24CL Co-axial vent plate.

Co-Linear with RA24CL

Overview

This appliance may ONLY be installed in an existing unaltered, functioning solid-fuel burning fireplace with a working flue and constructed of non-combustible material.

This appliance may be installed in outdoor, weather protected environments as defined in the GV60CKO Outdoor Conversion Kit instruction manual.

DO NOT install into combustible construction. This appliance is NOT APPROVED for installation with a zero clearance kit.

WARNING

Some materials or items, although safe, may discolor, shrink, warp, crack, peel, and so on because of the heat produced by the fireplace. Avoid placing candles, paintings, photos, and other items sensitive to heat around the fireplace.

WARNING

HOT HEARTH / FLOOR! The hearth or floor in front of the fireplace may become very hot when the fireplace heats. Do not use the hearth as a seat or shelf. Solid wood flooring in front of the fireplace (if allowed) may shrink during the heating season due to heat.

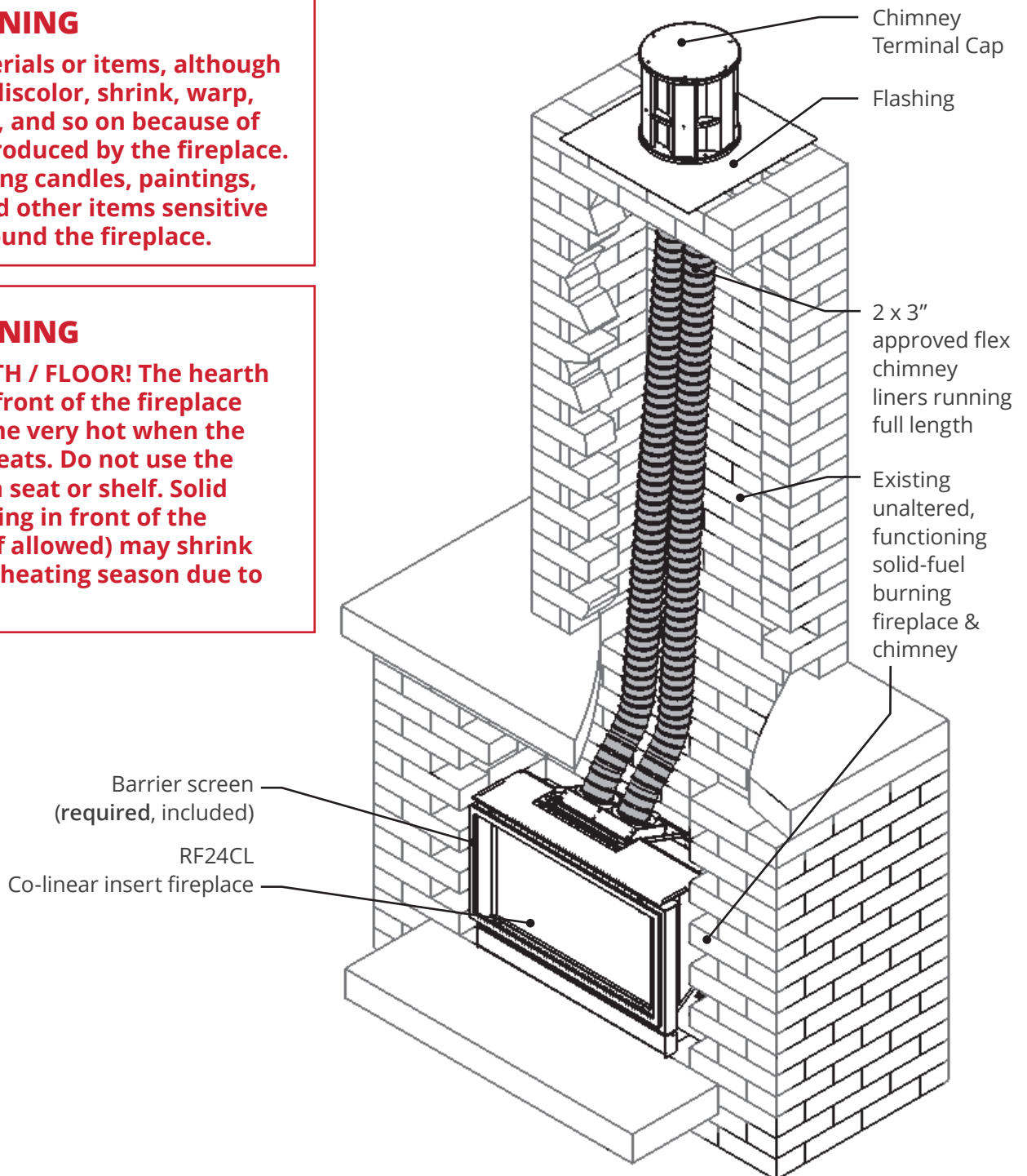

Co-Linear with RA24CL

Overview

Co-Linear Vent Plate RA24CL

Rear view

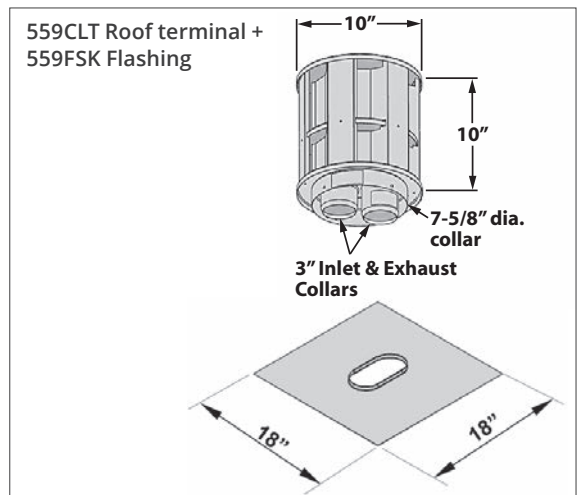
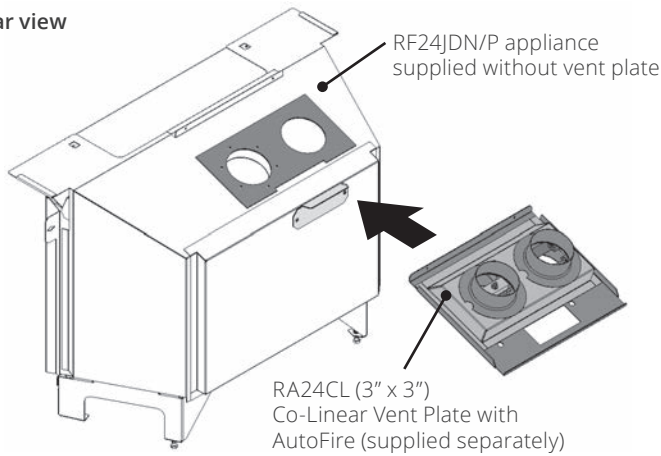

RF24JD with RA24CL—Co-Linear Vent Plate

Co-linear installation into existing F/P

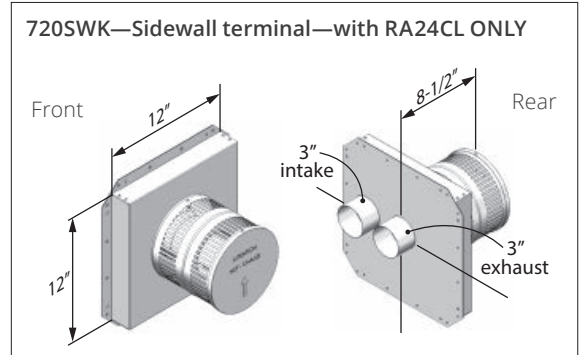
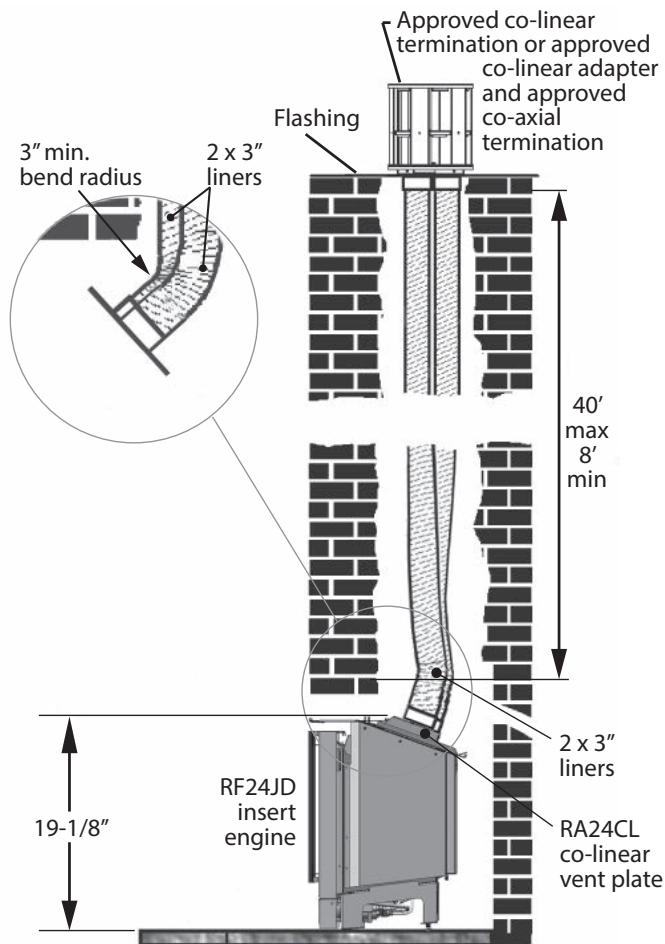

RF24JD with RA24CL + 720SWK—Sidewall Kit

Sidewall co-linear installation into existing F/P using 720SWK—(see installation instructions supplied with 720SWK)

Terminal Clearances: see 720SWK Clearances on page 15.

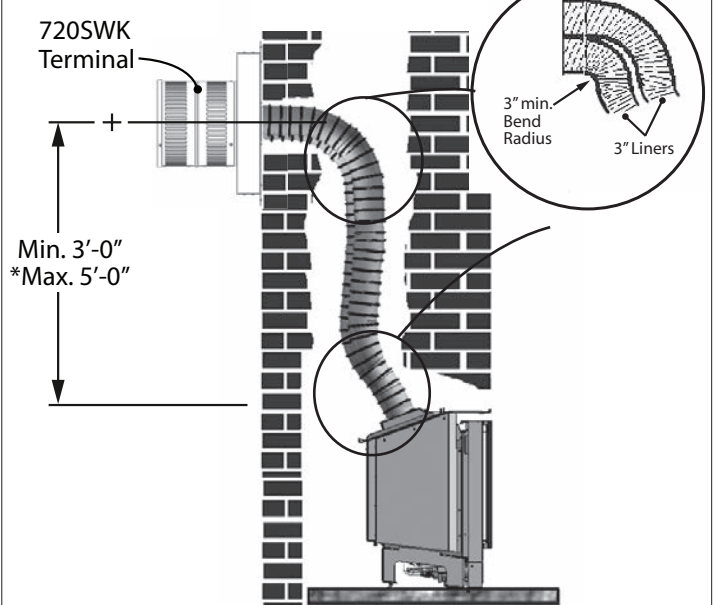

*Between 3' and 5' fully open restrictors. Beyond 5'-0", the sidewall terminal may be used but leave restrictors opened at mid-point as supplied.

Co-Linear with RA24CL

Dimensions

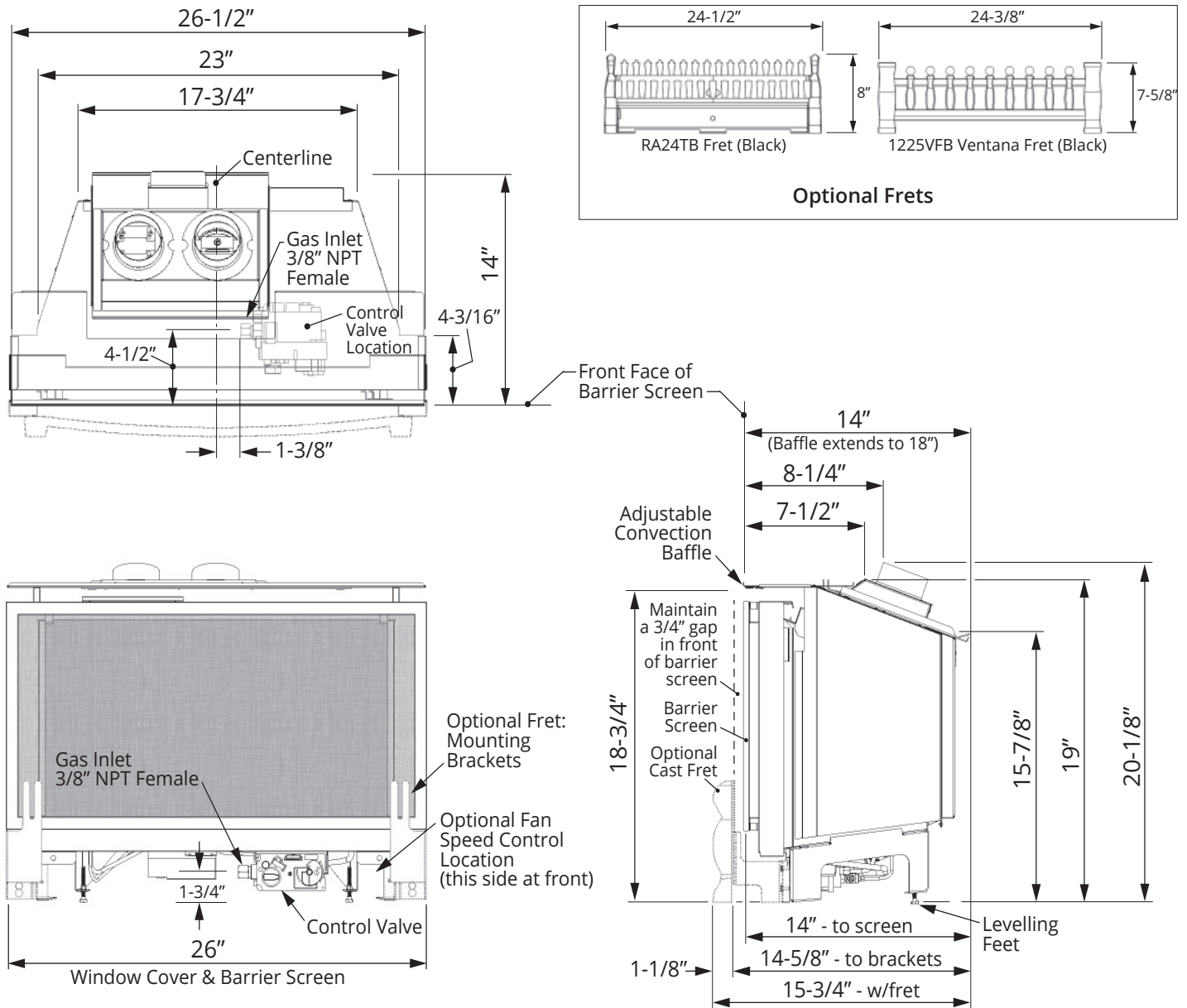

Minimum Cavity Dimensions

The diagram shows minimum dimensions required to install the RF24. Cavities having a combination of all the minimum dimensions shown possible, may prove to be difficult installations.

IMPORTANT! A free space of 3/4 inch (19 mm) is required in front of the barrier screen to allow the window to move and relieve during a hard start. The use of the optional fret sets this space with the fret bracket installed.

However, when the fret is not used and the bottom cover is used instead, this space immediately in front of the barrier screen must be added to the minimum depth as a safety precaution. **It is very important to ensure that the area immediately in front of the barrier screen is kept clear at all times even when not using a fret.**

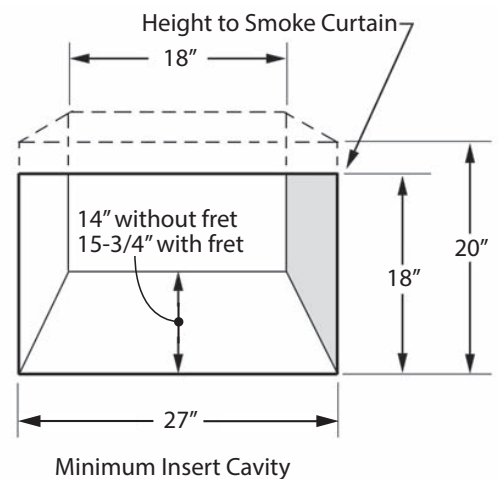

Co-Linear with RA24CL

Typical Vent Installation

Typical Vent Installation

See *Approved Venting Components* on page 9 of this manual.

Vent Location

The vent terminal must be located through the roof. This direct vent appliance is designed to operate when an undisturbed airflow hits the outside vent terminal from any direction.

Check local codes for allowable vertical vent termination.

Venting Table

Maximum vertical height	40 ft (measured to bottom of termination)
Minimum vertical height	8 ft (measured to bottom of termination)
Maximum horizontal run	4 ft (measured center to center of pipe)
Maximum offset angle	45° (sweeping bend to allow for obstructions)

Venting Notes

Where possible, avoid splicing flex pipes.

Co-linear installations ONLY. If splices are required, use an approved connector and seal joints with RTV high temp sealant.

Four feet horizontal is permissible to allow for routing around masonry projections. Do not bend flex pipe over a 45 degrees radius.

- Co-linear venting may be converted to solid 4" x 6-5/8" co-axial venting at the top of the existing solid-fuel burning chimney as necessary where the existing chimney has deteriorated and been removed. The conversion must be done using approved components (see page 9) and proper vent clearances to combustibles must be maintained.
- Flex liners may only be installed into solid-fuel burning fireplaces and chimney systems (no combustible constructions).
- The appliance must not be connected to a chimney flue serving a separate solid-fuel burning appliance.

Note

This appliance may also be vented using the optional 720SWK—Co-Linear Sidewall Kit as shown on page 11. See installation instructions packaged with the kit.

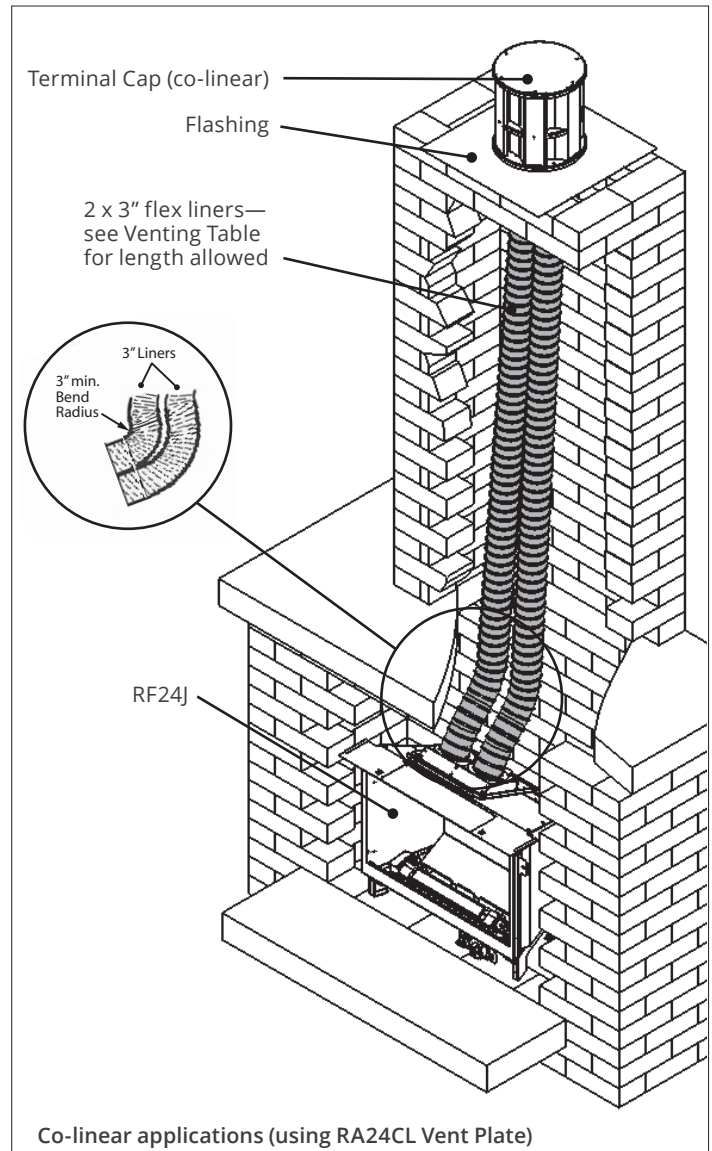

NOTE

Co-linear or co-axial flexible aluminum venting liners should be professionally inspected periodically for corrosion and damage and replaced when necessary. If the installation does not allow for future inspection or replacement of the flexible aluminum liners, then stainless steel vent liners are recommended.

Co-Linear with RA24CL

Vent Termination

Vent Termination

Co-Linear—3" x 3" flex

Existing Square Chimneys

559CLT—Co-Linear Terminal and 559FSK—Square Flashing Kit are recommended—see list of approved venting accessories on page 9 for alternate venting components.

1. Cut flashing kit to size. Allow extra around perimeter for drip edge to be formed on site.
2. Seal flashing to top of chimney using sealant (not supplied).
3. Fasten terminal to flashing using sheet metal screws as shown.

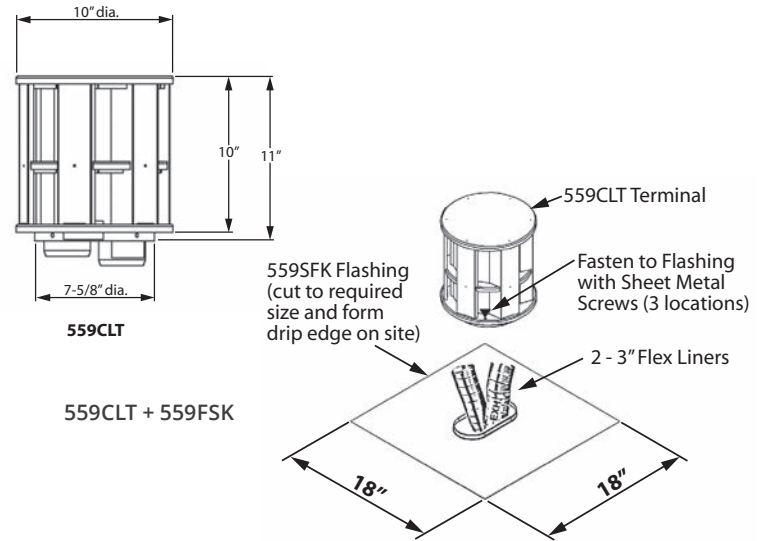

Existing Round Factory-Built Chimneys

The 559CLT terminal is designed to fit existing 7" or 8" diameter factory-built round chimneys without requiring additional flashing. Ensure the installation of the terminal seals off the top of the chimney space to avoid convective air loss. The diagrams below show a typical terminal installation for an 8" diameter air-cooled chimney system.

Sidewall Termination, ONLY with Valor 720SWK

See instructions provided with kit.

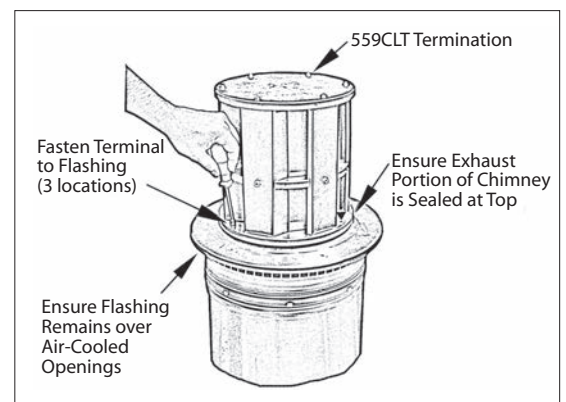
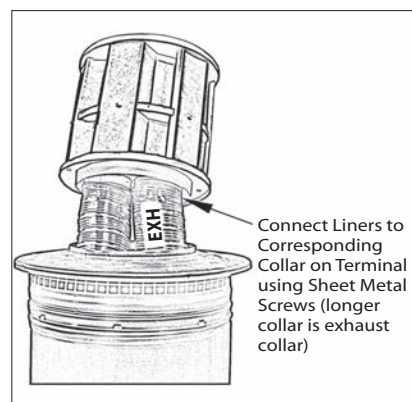
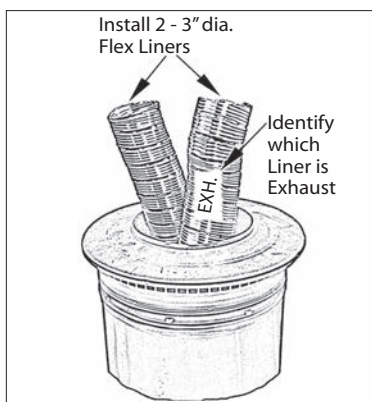
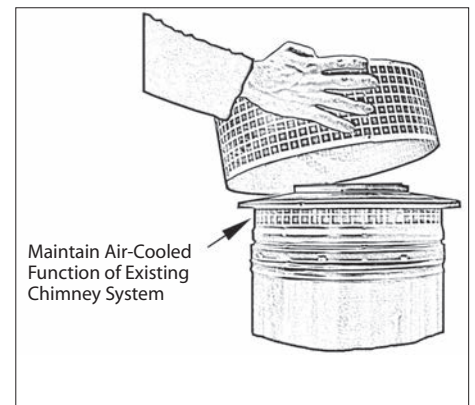
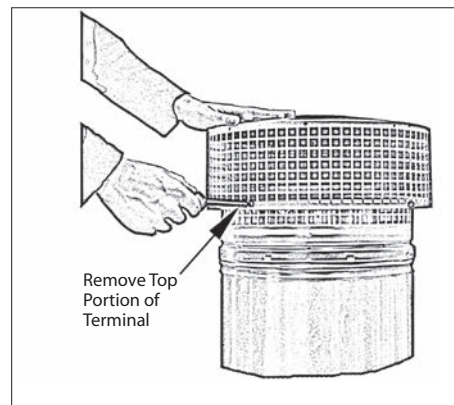
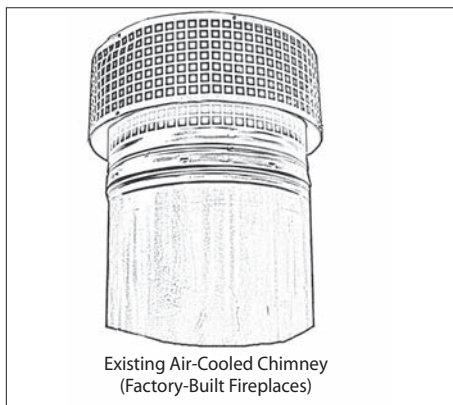
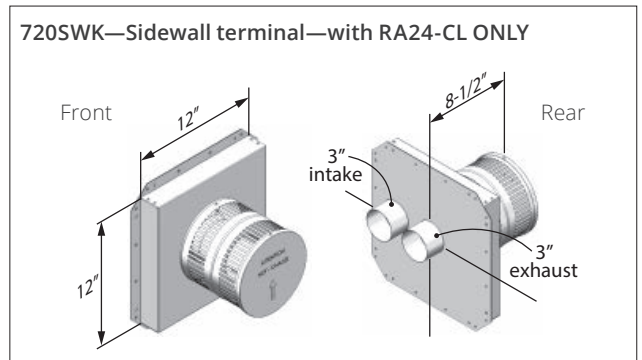

Co-Linear with RA24CL

720SWK Clearances

Horizontal Vent Termination Location

- The vent terminal must be located on an outside wall or through the roof.
- This direct vent appliance is designed to operate when an undisturbed airflow hits the outside vent terminal from any direction.
- The minimum clearances from this terminal that must be maintained when located on an outside wall are shown in figure below. Any reduction in these clearances could result in a disruption of the

airflow or a safety hazard. Local codes or regulations may require greater clearances.

- The vent terminal must not be recessed into a wall or siding.
- The vent terminal should be positioned where any snowdrifts will not cover it.
- Sidewall vent terminations require a terminal guard such as 658TG or 845TG when accessible—within 7' of ground.

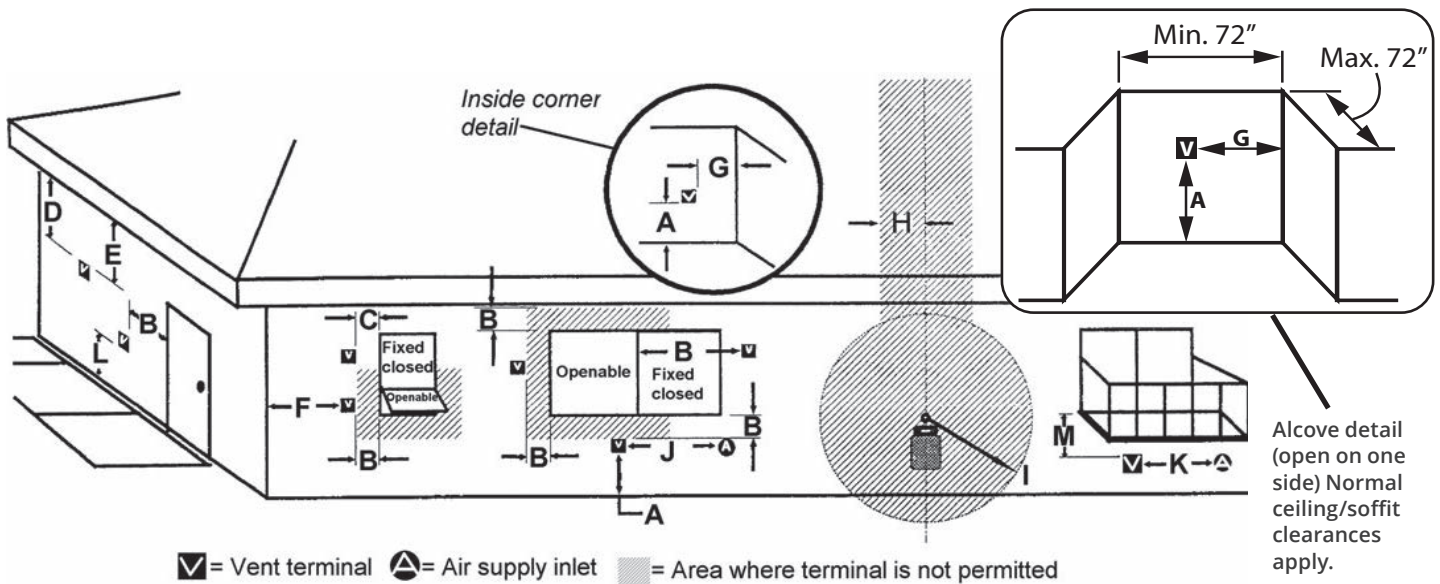

KEY	VENT TERMINAL LOCATIONS - MINIMUM DISTANCES	MINIMUM CLEARANCE	
		Inches	Cm
A	Clearance above grade, verandah, porch, deck or balcony	12	30
B	Clearance to window or door that may be opened	12	30
C	Clearance to permanently closed window (recommended to prevent condensation on window)	12	30
D	Vertical clearance to ventilated soffit located above the terminal within a horizontal distance of 2 feet (60 cm) from the center-line of the terminal	18	46
E	Clearance to unventilated soffit	12	30
F	Clearance to outside corner (measured from the center of vent)	12	30
G	Clearance to inside corner (measured from the center of vent)	12	30
H	Horizontal clearance to center-line of meter/regulator assembly located within 15 feet (4.6 m) below the terminal	36	90
I	Clearance to service regulator vent outlet	36	90
J	Clearance to non-mechanical air supply inlet to the building or the combustion air inlet to any other appliance	12	30
K	Clearance to a mechanical air supply inlet	72	180
L	Clearance above paved sidewalk or a paved driveway located on public property Note: A vent must not terminate directly above a sidewalk or paved driveway, which is located between two single-family dwellings and serves both dwellings. THIS DOES NOT APPLY to direct vent, non-condensing appliances in the Province of Ontario.	84	210
M	Clearance under a verandah, porch, deck or balcony Only permitted if veranda, porch, deck or balcony is fully open on a minimum of 2 sides beneath the floor	12	30

Note: Local codes and regulations may require different clearances.

Co-Axial with RA24CA

Overview

This appliance may ONLY be installed in an existing unaltered, functioning solid-fuel burning fireplace with a working flue and constructed of non-combustible material.

This appliance may be installed in outdoor, weather protected environments as defined in the GV60CKO Outdoor Conversion Kit instruction manual.

DO NOT install into combustible construction. This appliance is NOT APPROVED for installation with a zero clearance kit.

WARNING

Some materials or items, although safe, may discolor, shrink, warp, crack, peel, and so on because of the heat produced by the fireplace. Avoid placing candles, paintings, photos, and other items sensitive to heat around the fireplace.

WARNING

HOT HEARTH / FLOOR! The hearth or floor in front of the fireplace may become very hot when the fireplace heats. Do not use the hearth as a seat or shelf. Solid wood flooring in front of the fireplace (if allowed) may shrink during the heating season due to heat.

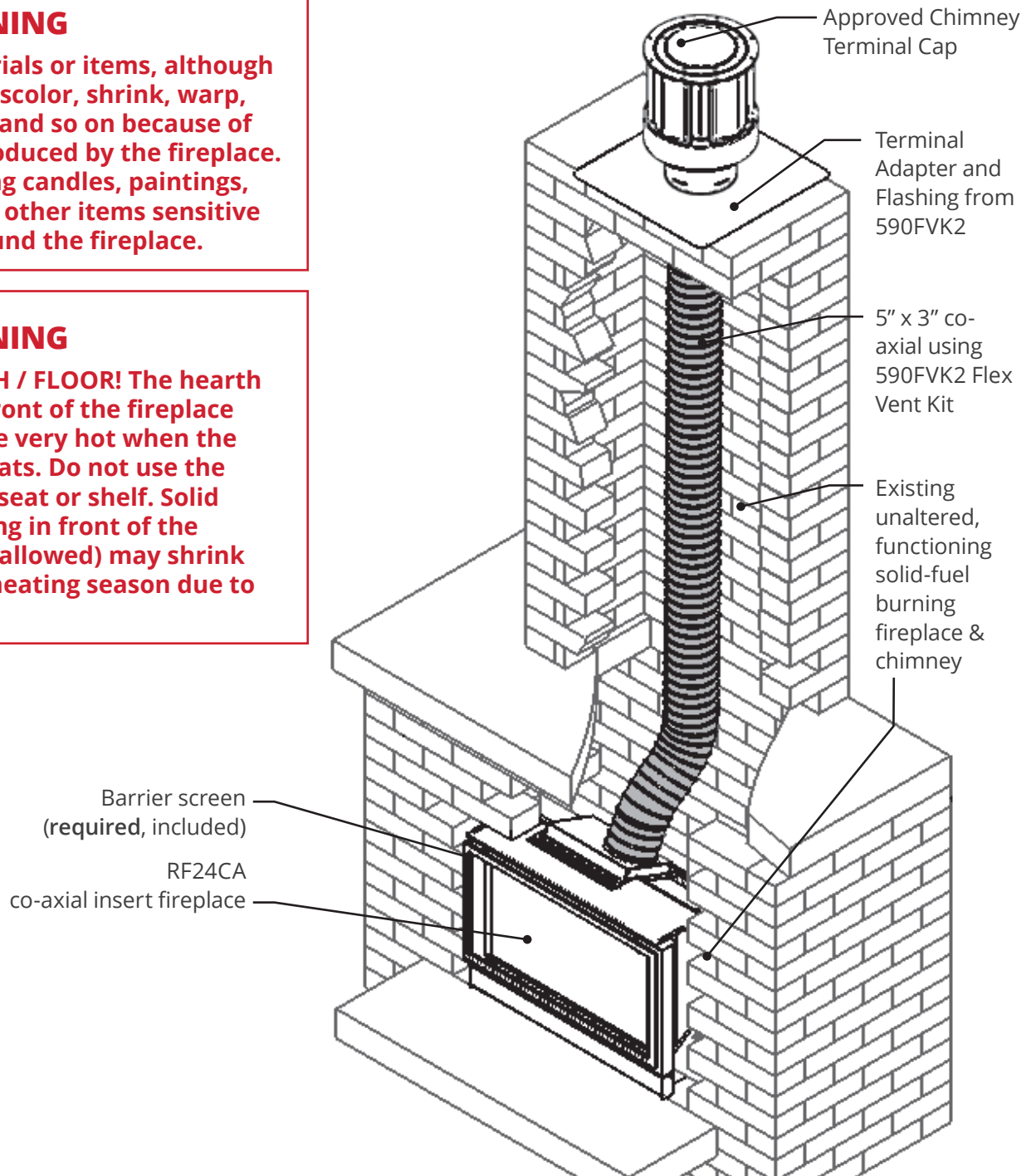

Co-Axial with RA24CA

Overview

Co-axial Vent Plate

Rear view

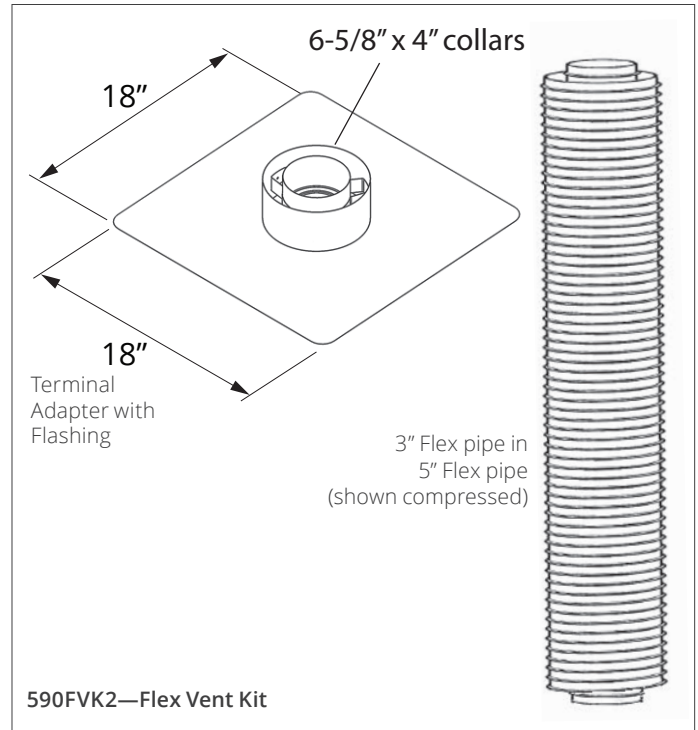
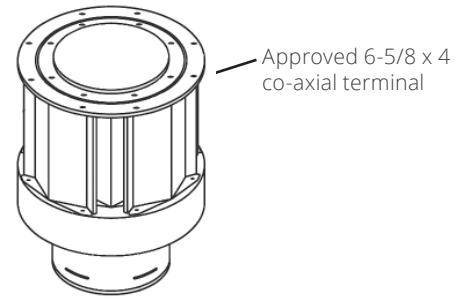
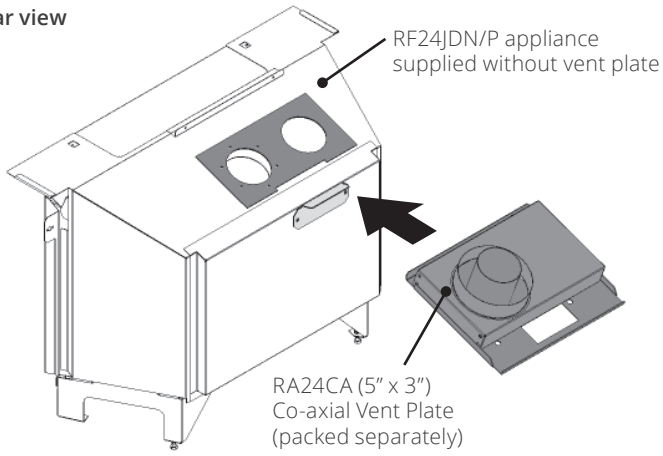

RF24JD with RA24CA—Co-axial Vent Plate

Co-linear installation into existing F/P

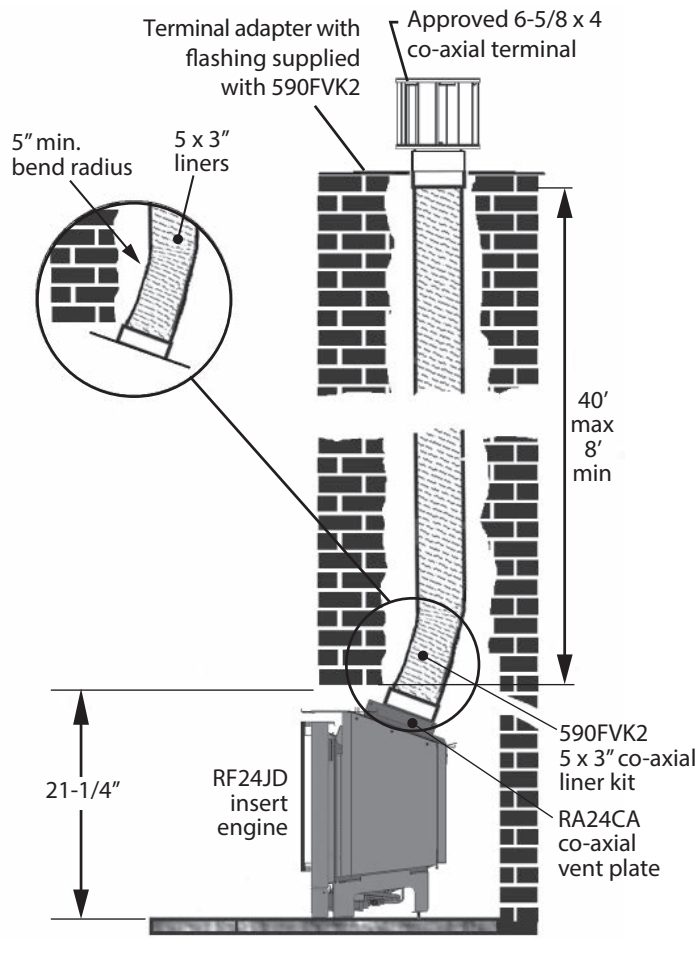

Co-Axial with RA24CA

Dimensions

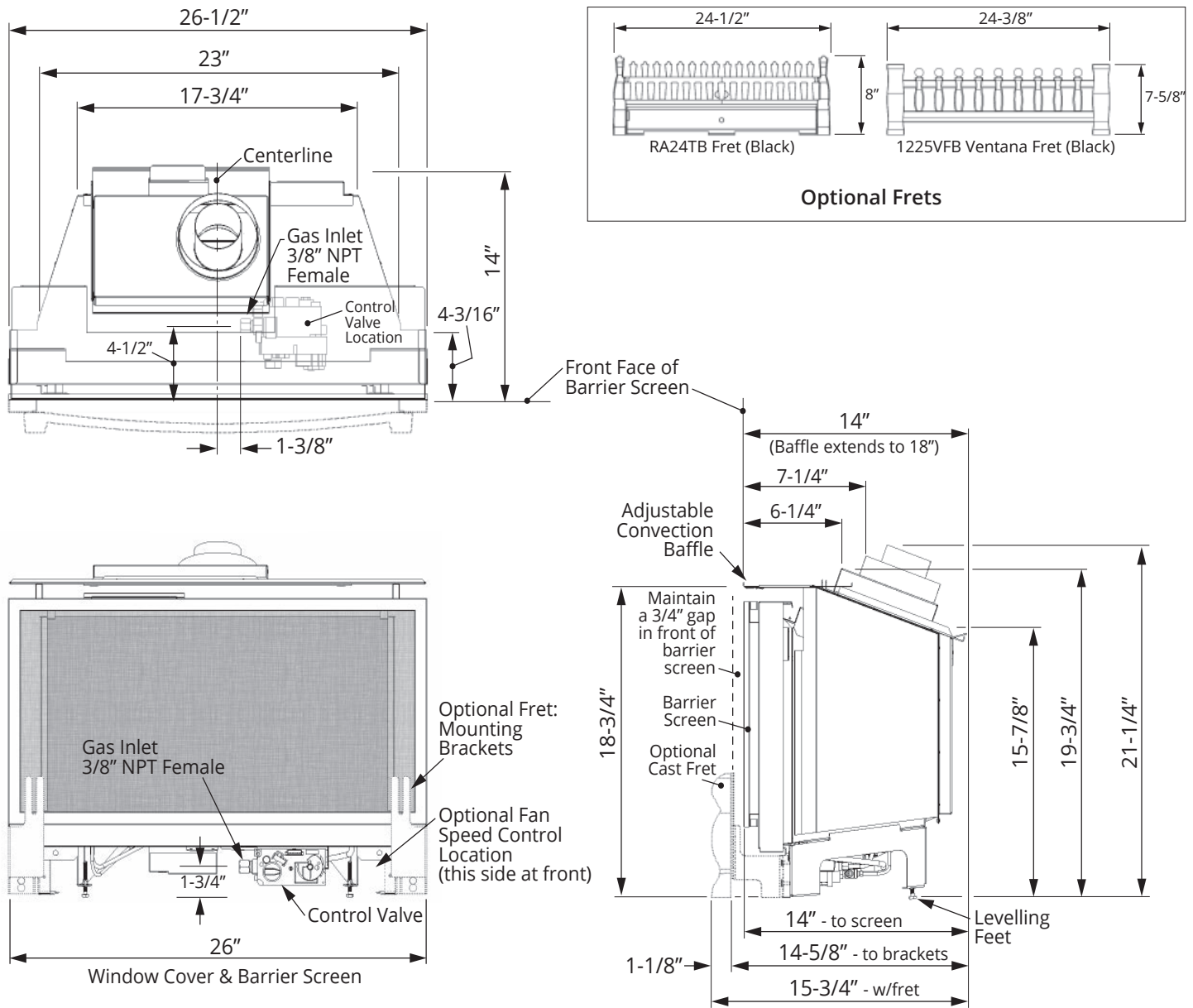

Minimum Cavity Dimensions

The diagram shows minimum dimensions required to install the RF24. Cavities having a combination of all the minimum dimensions shown possible, may prove to be difficult installations.

IMPORTANT! A free space of 3/4 inch (19 mm) is required in front of the barrier screen to allow the window to move and relieve during a hard start. The use of the optional fret sets this space with the fret bracket installed.

However, when the fret is not used and the bottom cover is used instead, this space immediately in front of the barrier screen must be added to the minimum depth as a safety precaution. **It is very important to ensure that the area immediately in front of the barrier screen is kept clear at all times even when not using a fret.**

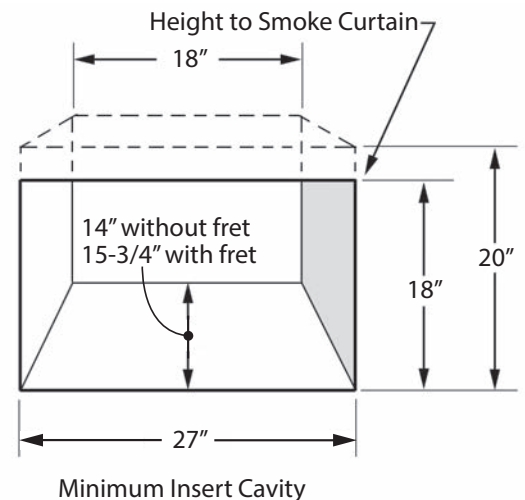

Co-Axial with RA24CA

Typical Vent Installation

Typical Vent Installation

See *Approved Venting Components* on page 9 of this manual.

Vent Location

The vent terminal must be located through the roof. This direct vent appliance is designed to operate when an undisturbed airflow hits the outside vent terminal from any direction.

Check local codes for allowable vertical vent termination.

Venting Table

Maximum vertical height	40 ft (measured to bottom of termination)
Minimum vertical height	8 ft (measured to bottom of termination)
Maximum horizontal run	4 ft (measured center to center of pipe)
Maximum offset angle	45° (sweeping bend to allow for obstructions)

Venting Notes

Where possible, avoid splicing flex pipes.

Four feet horizontal is permissible to allow for routing around masonry projections. Do not bend flex pipe over a 45 degrees radius.

- Flex liners may only be installed into solid-fule burning fireplaces and chimney systems (no combustible constructions).
- The appliance must not be connected to a chimney flue serving a separate solid-fuel burning appliance.

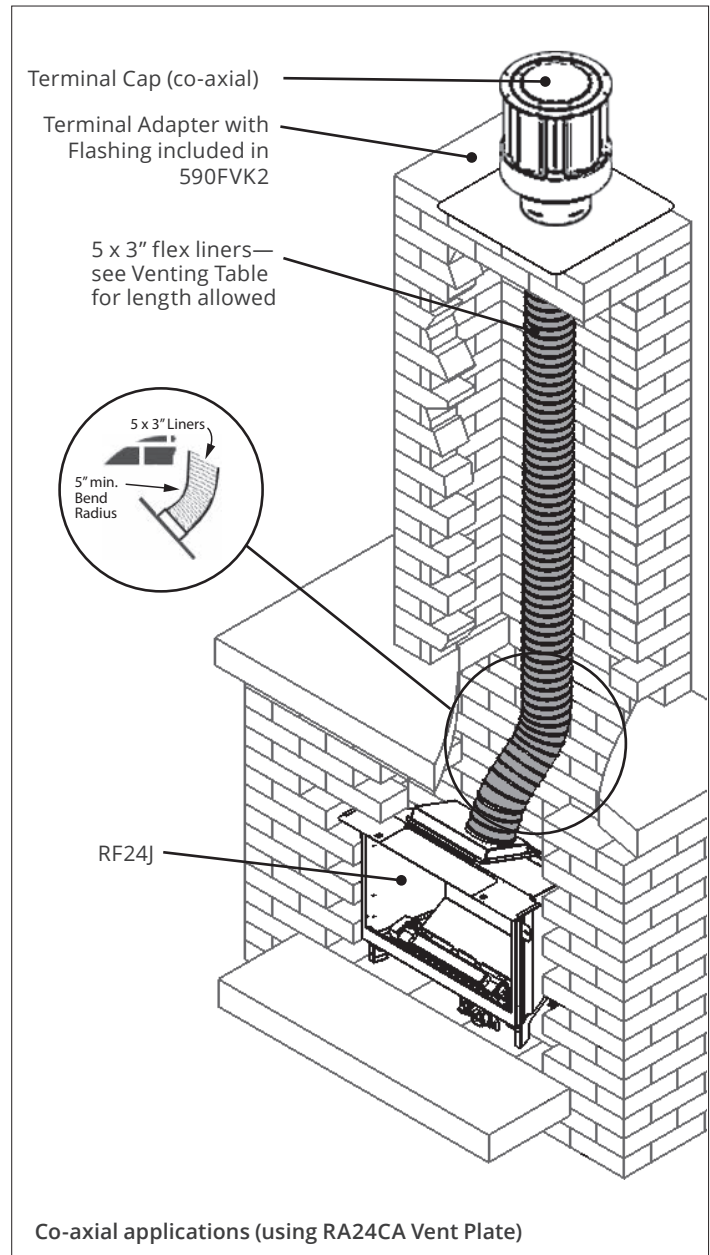

NOTE

Co-linear or co-axial flexible aluminum venting liners should be professionally inspected periodically for corrosion and damage and replaced when necessary. If the installation does not allow for future inspection or replacement of the flexible aluminum liners, then stainless steel vent liners are recommended.

Co-Axial with RA24CA

Vent Termination

Co-Axial—5" x 3" flex

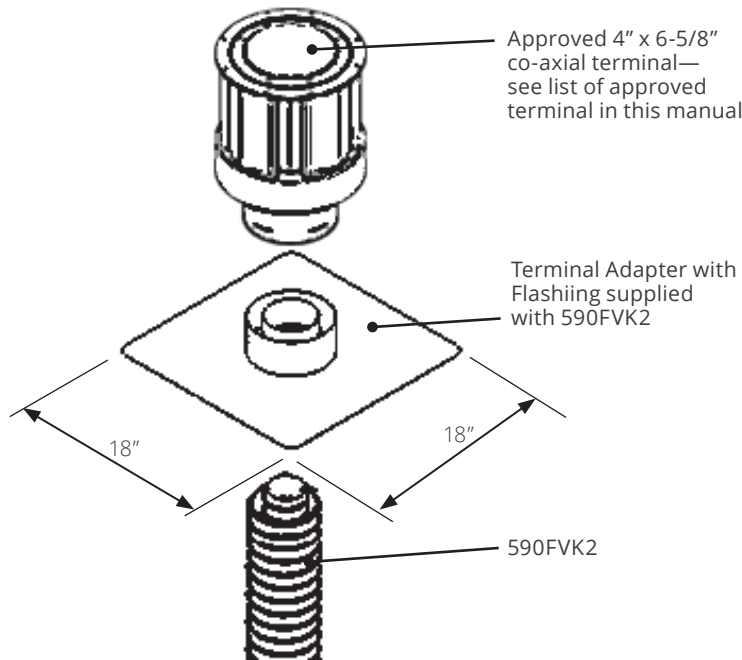

Co-Axial + Co-Linear

Vent Terminal Location

Vent Terminal Location

The venting system for this appliance is considered to be a Special Venting System. The rule in the Installation Code CAN/CGA-B149 requiring a minimum vent height of 2 feet above any portion of a building within 10 feet does not, therefore, apply.

Clearances for Vent Terminals (Co-Linear and Co-Axial)

Roof Pitch	Minimum 'H' (feet)
Flat to 7/12	1'
over 7/12 to 8/12	1.5'
over 8/12 to 9/12	2'
over 9/12 to 10/12	2.5'
over 10/12 to 11/12	3.25'
over 11/12 to 12/12	4'
over 12/12 to 14/12	5'

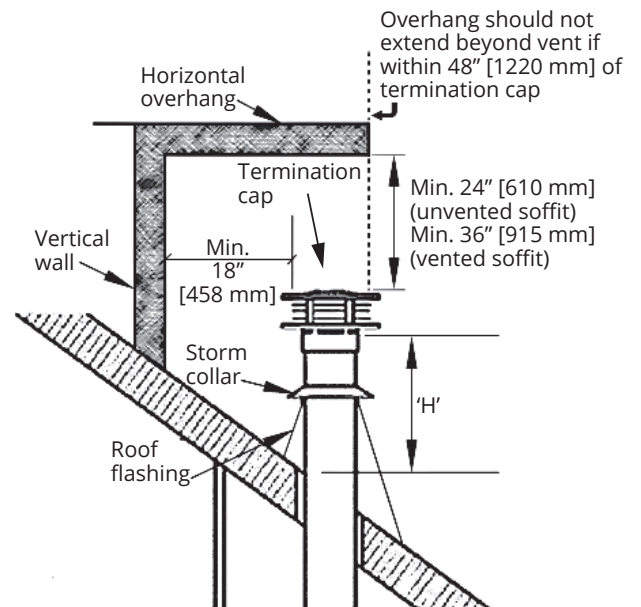

Preparation

Existing Fireplace Preparation

A few points must be considered before inserting the RF24 into an existing fireplace cavity. Generally, no modifications are allowed to the existing fireplace that will compromise the integrity of the existing fireplace.

Components that are bolted or screwed on such as dampers or baffles may be removed to accommodate the installation of the RF24 engine. Refractory bricks and log grates may also be removed.

Cutting away any sheet metal parts of the existing fireplace to accommodate the installation of the RF24 is prohibited.

Check with local authorities if in doubt.

Clean Fireplace and Chimney

Have the chimney swept and the fireplace cavity including ash dumps and clean-outs cleaned before installing the RF24 heater and vent liners. Any creosote or soot residue remaining in the fireplace cavity chimney or clean-out may cause odors or stains once the RF24 insert is installed. Consult with chimney sweep for information on how best to clean.

Existing Dampers

Factory-built, zero-clearance fireplaces will require the damper to be removed in order to install the vent liners. These dampers are usually bolted into place. Dampers in masonry fireplaces must be fixed open and may remain in place.

Ash Retaining Curbs

Some fireplaces (particularly factory-built) have a raised curb at the front edge to retain ashes. Check the dimensions carefully to ensure the RF24 engine will fit behind any raised curb (some curbs may be removed separately from the refractory base).

Existing Fireplace Preparation

Gas Line Routing

Plan the routing of the gas line before proceeding. Utilize the existing hole for the gas line of the factory-built fireplace.

If the fireplace has no access hole, carefully drill an access hole of 1.5 inch (38 mm) or less through the lower sides or bottom of the firebox. The access hole must be plugged with non-combustible insulation after the gas supply line has been installed.

See Dimensions section for detailed location of gas inlet. Also, take into consideration whether or not a fan or shut-off valve will interfere when planning routing of the gas line.

Existing Glass Doors and Wire Screens

Existing glass doors must be permanently removed prior to installing the RF24 insert.

Combustible Mantels

Combustible mantel clearances must conform to those required for the original solid-fuel fireplace into which the RF24 is being installed.

Attach Warning Conversion Plate to Existing Fireplace

(plate supplied loose with RF24 heater)

Attach the "This fireplace has been converted..." label to the existing fireplace using screws or other mechanical means and store any removed parts in back of the existing fireplace for future use.

Preparation

Before Installation



Caution

Only qualified, licensed, or trained personnel should install this appliance.

Installer - READ THIS FIRST!

1. YOU NEED TO KNOW FROM THE HOMEOWNER:
 - What vent configuration will be installed;
 - What is the required cavity size/hearth finish;
 - Will a fret be used;
 - Will there be any optional accessories.
2. Unpack the appliance, removing all items packed inside and around it. Recycle the packaging.
3. Check that you have everything, using the Pack Content sheet. Also, check that you have:
 - VENT PLATE
 - Fuel bed (packed separately)
 - Venting accessories
 - Gas conversion kit (if necessary)
 - Optional accessories (if used)
 - Electrical accessories (if used)*
4. Carefully read the Installer's Checklist included with the fireplace for the installation sequence.



WARNING

*** NO ELECTRICAL CONNECTION ALLOWED
for any outdoor installation!**

Installation

Prepare Appliance

The size of the existing fireplace cavity will affect the method of installation. Smaller fireplaces, particularly factory-built zero-clearance fireplaces will require the RF24 firebox to be disassembled then reassembled inside the fireplace. Plan your particular installation accordingly.

Remove Window

1. Unhook barrier screen and window cover. The screen is hooked to the window cover which in turn is hooked to the fireplace at the top and attached with magnets at the bottom. Grabbing both the screen and window cover, pull the bottom to detach the magnets and unhook the top.

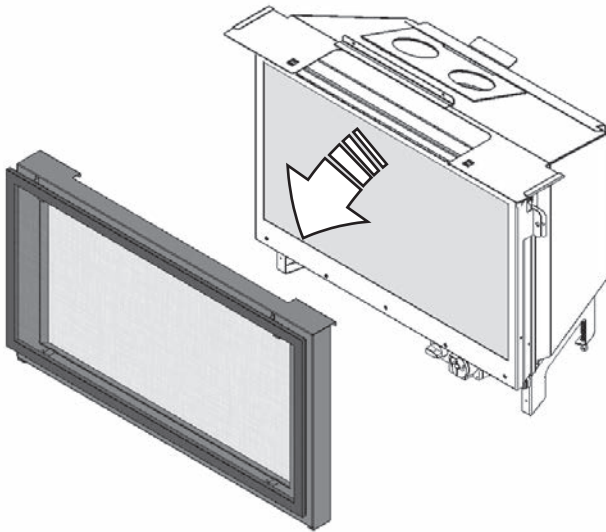

2. Remove window. Rotate the four fastening studs at the bottom corners and sides 90 degrees to release them. Unhook window and keep in a safe place.

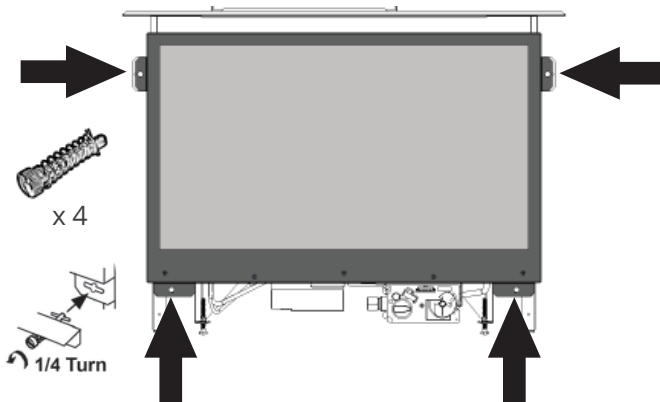

Window & Burner Removal

3. Remove items packed inside firebox.
4. Strip firebox down by removing:
 - a. Log support (4 screws);
 - b. Burner module (10 screws);
 - c. Support legs (2 screws per leg) (required when inserting into small fireplaces only).

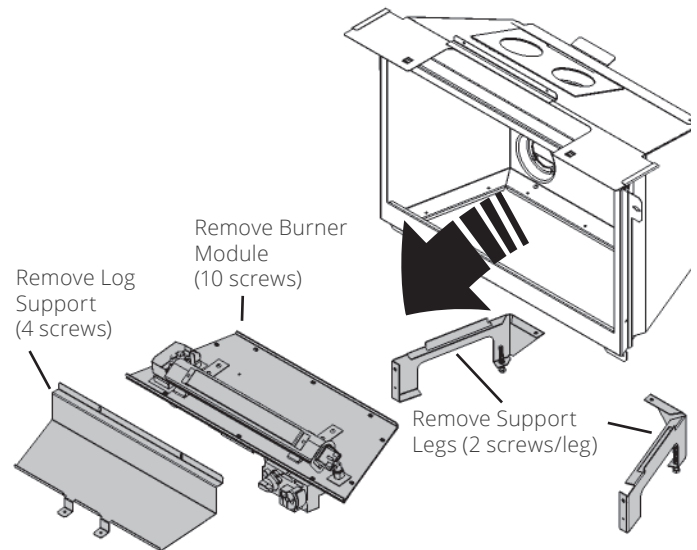

Installation

Install Vent Plate

Install Vent Plate to Appliance

Install either the co-linear vent plate RA24CL or the co-axial vent plate RA24CA.

Slide the chosen vent plate over the appliance's rear cleat then secure to front flange with two screws.

NOTE

If the cavity where the appliance is to be installed is small, you may want to secure the plate to the liners first then slide the plate with liners attached onto the appliance in the cavity—see next pages for more information.

In all case, ensure the plate is hooked to the cleat at the back of the appliance!

Co-Linear Vent Plate RA24CL

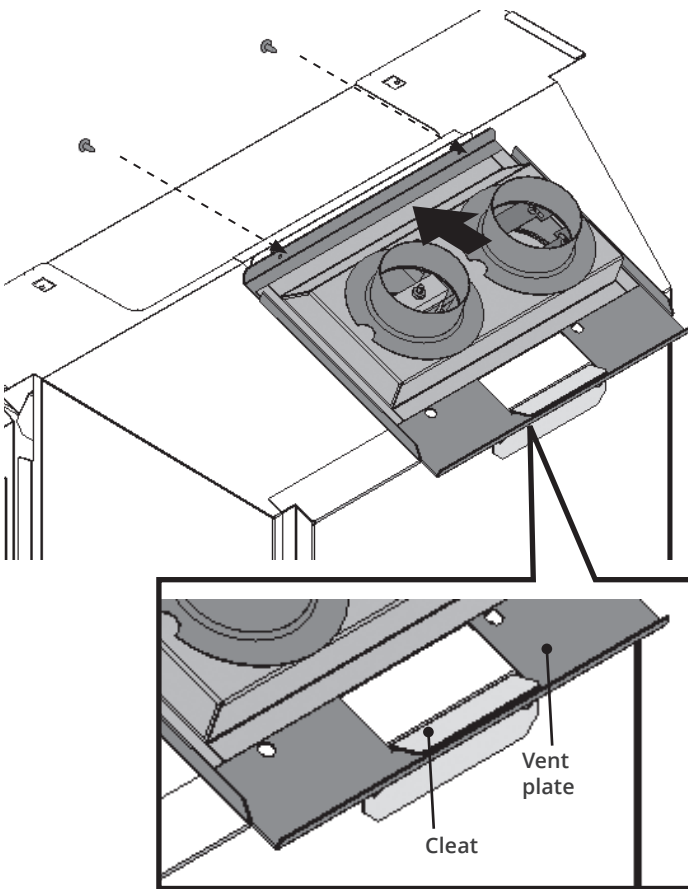

Co-Axial Vent Plate RA24CA

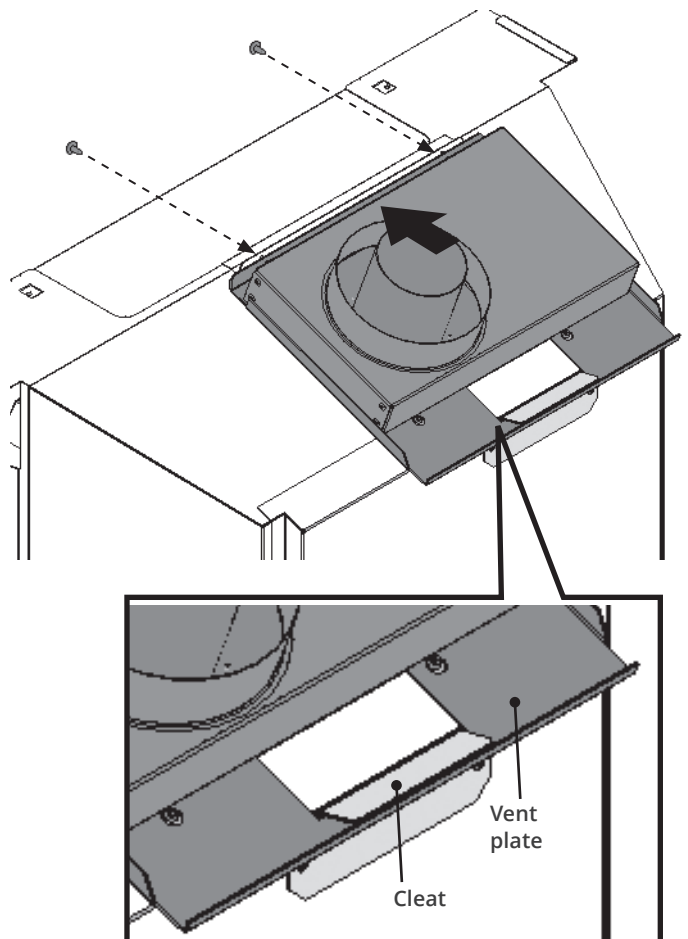

IMPORTANT! When installing vent plate, ensure rear edge of plate is hooked to cleat!

Installation

Connect Venting—Co-Axial

Connect Venting Using RA24CA Co-Axial Vent Plate with 3" x 5" liners from 590FVK2

IMPORTANT: This appliance's venting system is room sealed and therefore, does not require room air to be used in the combustion process.

1. Stretch 3" and 5" liners from kit 590FVK2 individually to required length. Insert the 3" liner inside the 5" liner and rough-in vent liners into the existing chimney system from the roof. Be careful not to tear or damage the liners in the process. Verify there is plenty of liner at the bottom to facilitate the connection of the liners to the vent slider so you will not need to stretch more later.
2. Trim 590FVK2's Terminal Adapter & Flashing as required to suit top of chimney and fold a drip edge if desired.
3. Trim ends of liner if necessary and fasten to collars on the underside of the 590FVK2's terminal adapter using sheet metal screws and gear clamps provided. Ensure liners are well secured and will not fall down the chimney.
4. Apply a bead of sealant to top of chimney and seat 590FVK2's flashing onto sealant.
5. Release the two screws retaining the vent slider plate to the front of the firebox. Remove the plate from the firebox by sliding it towards the back of the firebox.
6. Fit the two liners. Secure with hose clamps (included) and 2 tapping screws per liner (inner liner first, then outer).
7. Slide the firebox onto the vent slider in the cavity taking care not to damage the liners. **Make sure that the rear edge of the slider is hooked over the cleat on the firebox.**

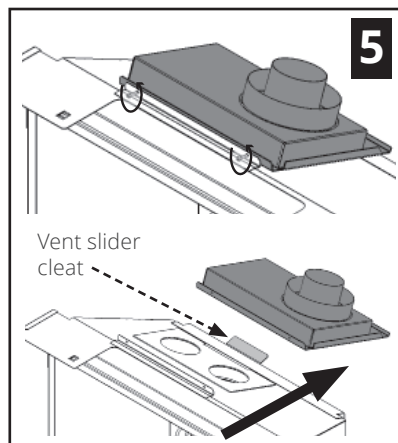

⚠ WARNING

Failure to position the parts in accordance with these diagrams or failure to use only parts specifically approved with this appliance may result in property damage or personal injury.

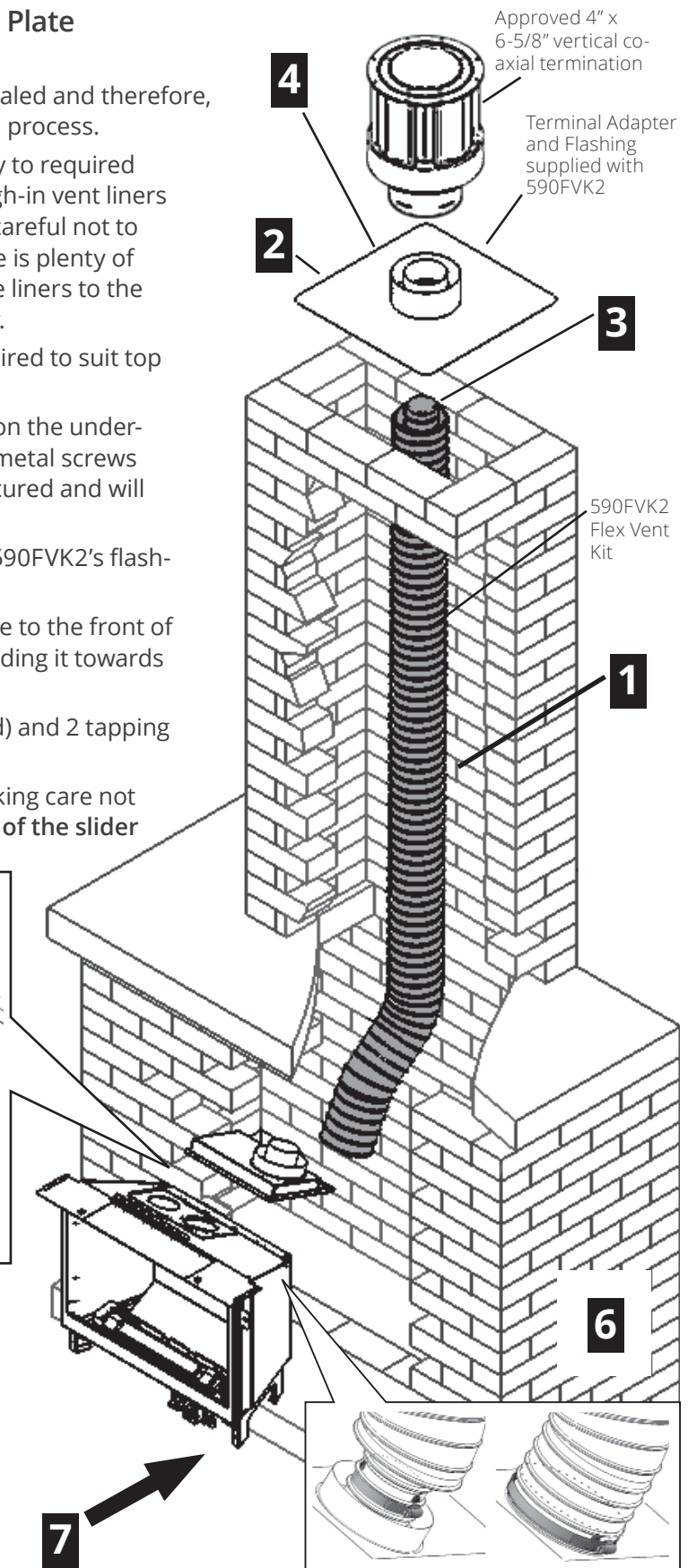

Installation

Reinstall Support Legs (if removed)

With the firebox recessed behind the smoke curtain of the existing fireplace, raise it and place the individual support legs underneath. Placing a temporary shim under the firebox, such as a 2" x 4", may help while positioning the support legs. Tabs are provided on the support legs to help position them. Fasten the support legs at the points indicated by the arrows using the bolts provided (2 per side).

Raise right side of firebox and slip RH support leg under. Fasten with 2 bolts as indicated.

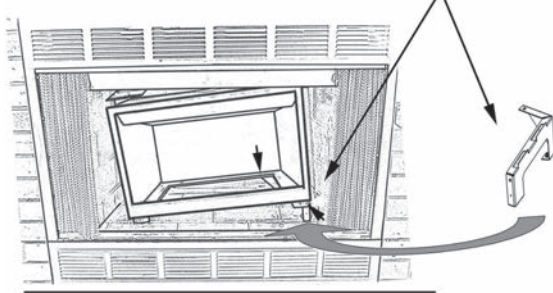

Raise left hand side of firebox and slip LH support leg under. Fasten with 2 bolts as indicated.

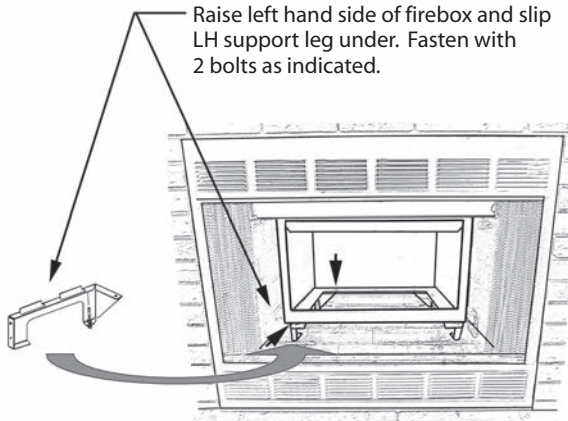

Level Firebox in Hearth

The backside of each support leg has a leveling bolt. If necessary, adjust the level of the firebox in the hearth.

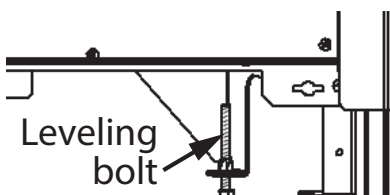
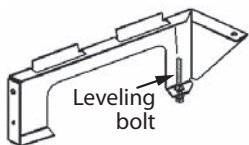

Front View

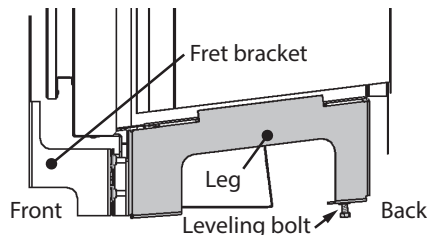

Side View

Reassemble Appliance

Reinstall Burner Module

NOTE: If the circulating fan is to be installed, it should be done at this point before installing the burner module. See instructions packaged with the fan for details of its installation.

Reinstall the burner module using the 10 screws removed previously.

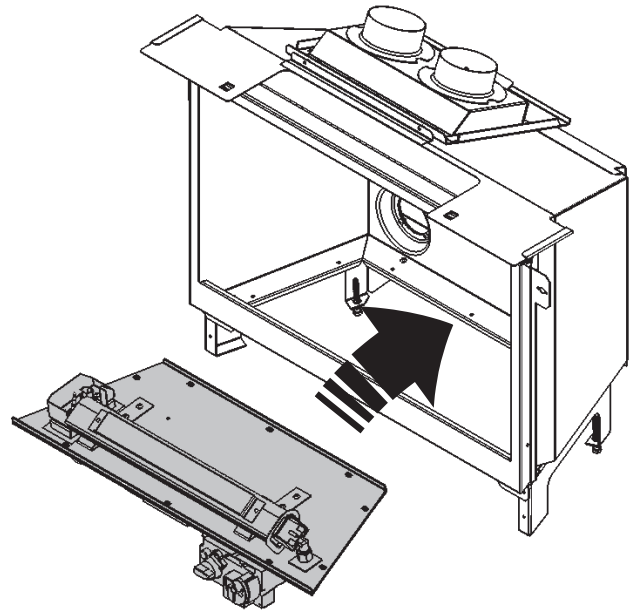

NOTE: The upper baffle may be removed to gain more room for the screwdriver to install the rear screws.

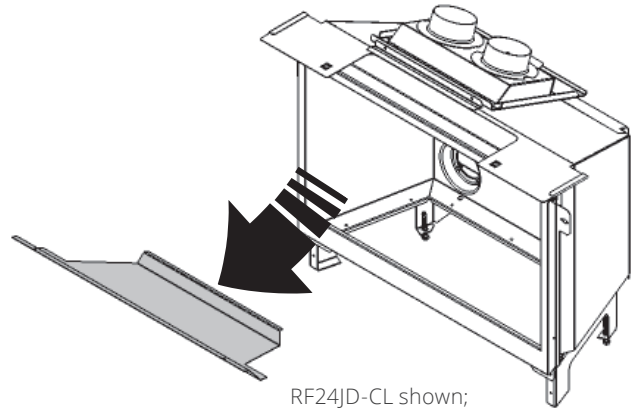

RF24JD-CL shown;
same for CA

Installation

Reinstall Log Support

RF24JD-CL
shown;
same for CA

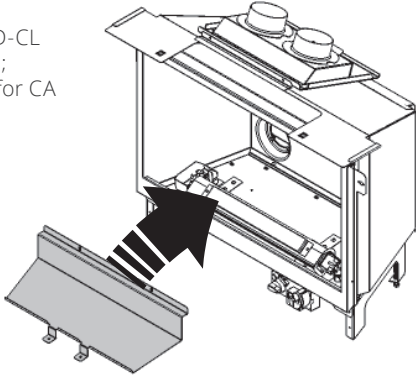

Reinstall Firebox Top Baffle (if removed)

Edge fits into
cleat at back

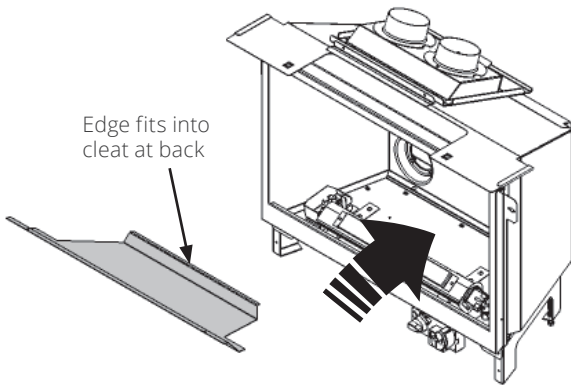

Install Top Convection Baffle

Place the firebox as far back as possible within the existing fireplace to allow ample space at front for the fret, if used, and to allow convection air to flow under the smoke curtain of the existing fireplace.

Slide the convection baffle into the clips located underneath top of appliance.

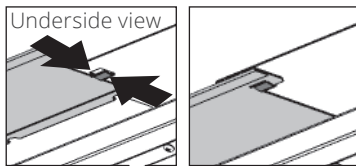

Clip convection baffle
to firebox

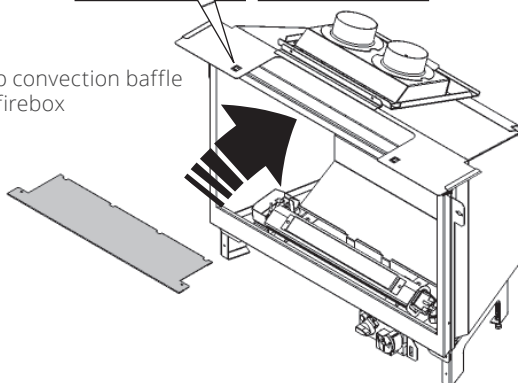

Reassemble Appliance

Install Convection Baffle Extension

Install the convection baffle extension, sliding it on top of the firebox into the guides on each side.

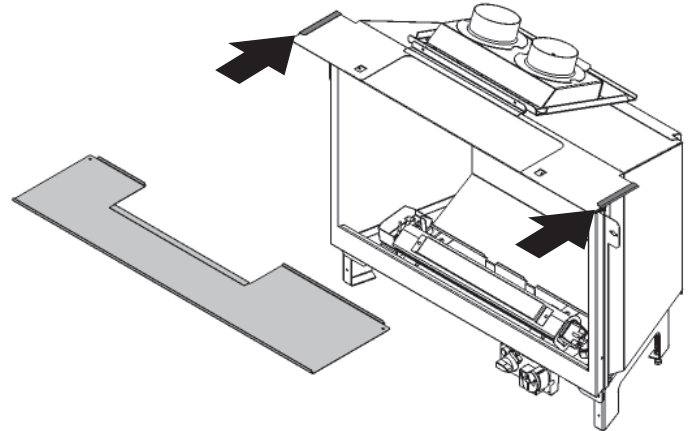

Slide the extension in or out to allow convection air to flow under the smoke curtain of the existing fireplace. At the maximum, the extension must cover the smaller convection baffle. At the minimum, the extension will be butted to the vent plate.

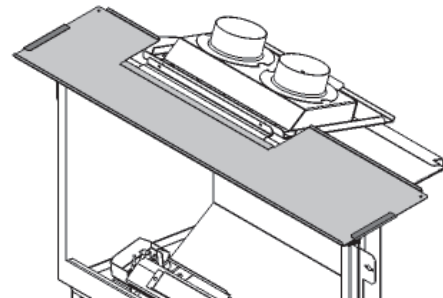
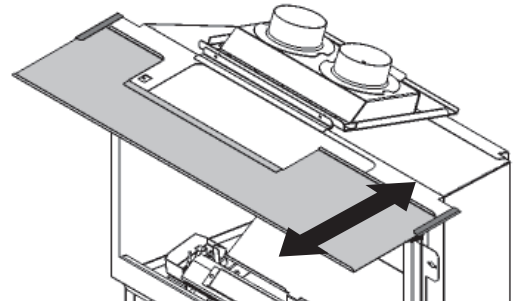

Installation

Connect Gas Supply

Connect Gas Supply

It is preferable to rough-in the gas line at this point before proceeding with the firebox installation.

The gas supply inlet connection is a 3/8" NPT female connector. For detailed location of this connector, see drawing in *Dimensions* on page 12 or page 18. If a circulating fan or isolating valve is to be installed, adjust the routing of the gas line to suit.

Use only new black iron or steel pipes, CSST, or copper tubing if acceptable—check local codes. **Note that in USA, copper tubing must be internally tinned for protection against sulfur compounds.**

Union in gas lines should be of ground joint type.

The gas supply line must be sized and installed to provide a supply of gas sufficient to meet the maximum demand of the appliance without undue loss of pressure.

Sealant used must be resistant to the action of all gas constituents including propane gas. Sealant should be applied lightly to male threads to ensure excess sealant does not enter gas lines.

The supply line should include a manual shut-off valve and union to allow the appliance to be disconnected for servicing.

Pressure test the supply line for leaks.

The appliance and its individual shut-off valve must be disconnected from the gas supply piping system during any pressure testing of that system at test pressures in excess of 1/2 psig (3.5kPa).

The appliance must be isolated from the gas supply piping system by closing its individual manual shut-off valve during any pressure testing of the gas supply piping system at test pressures equal to or less than 1/2 psig (3.5kPa).

Failure to either disconnect or isolate the appliance during pressure testing may result in regulator or valve damage. Consult your dealer in this case.

The minimum supply pressure is given on page 6 of this manual.

All piping and connections must be tested for leaks after installation or servicing. All leaks must be corrected immediately.

When testing for leaks:

- Make sure that the appliance is turned off.
- Open the manual shut-off valve.
- Test for leaks by applying a liquid detergent or soap solution to all joints. Bubbles forming indicate a gas leak.

WARNING

NEVER USE OPEN FLAME to check for leaks. Correct any leak detected immediately.

The pressure test tapping locations are shown below. A built-in non-adjustable regulator controls the burner manifold pressure. The correct pressure range is shown page 6 of this manual. The pressure check should be made with the burner alight and at its highest setting. See *Appendix A – Lighting Instructions Plate* on page 43 for full operating details.

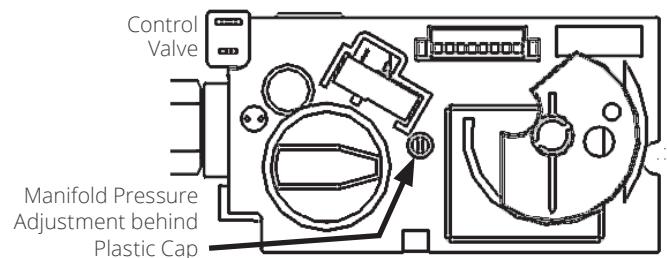
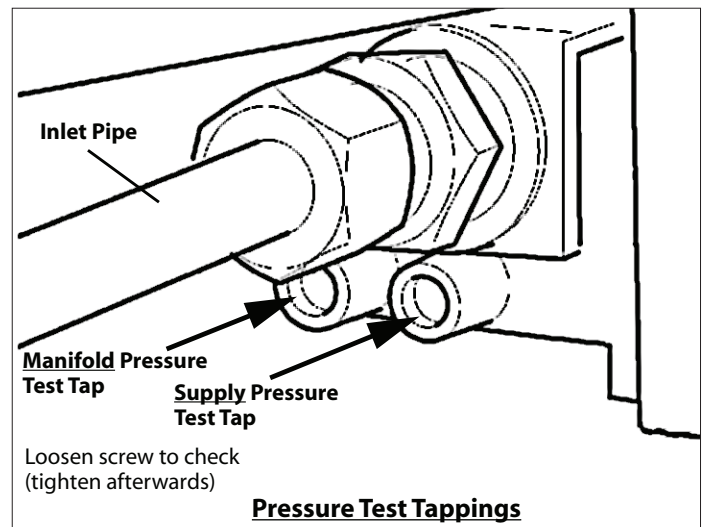

Connect Gas Line and Test Appliance

Connect the gas line to the burner module. Check for leaks, purge the line, and test-fire the unit before installing the window or proceeding with the remainder of the installation—see *Appendix A – Lighting Instructions Plate* on page 43.

Installation

Traditional Log Set MF28LSK

Material required

- Traditional Log Set containing:
 - 6 logs
- Gloves, if desired (not included)

Installation

Unpack the ceramic logs very carefully to avoid damaging their fragile material. Install the logs as shown below. **Please note that the position of the logs is critical to ensure the good performance of the appliance.**

1. Place the rear log on the sheet metal support. Pull it forward until the notch in the underside of the log sits against the front edge of the sheet metal support. Slide the log towards the left hand side until the notch in the log touches the right angled return edge of the pilot shield as indicated.



Rear log pushed to the left abuts the pilot shield

2. Place the front left log on the burner. Slide it towards the left until its narrow end rests in the notch of the rear log as indicated.

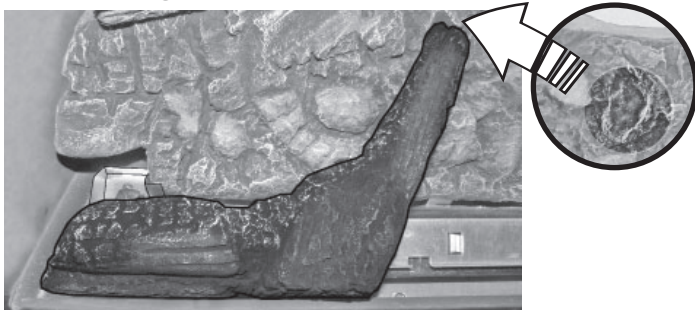

3. Place the top left log on the pin of the rear log. The bottom of the log rests on the left side and end of the front left log just installed.

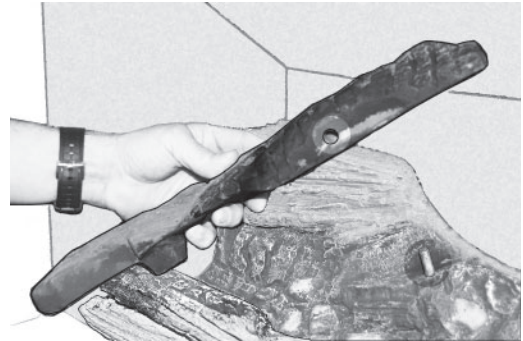

Note: Make sure the lower end of the top log rests on the front log as indicated and does not fall below in the firebox.

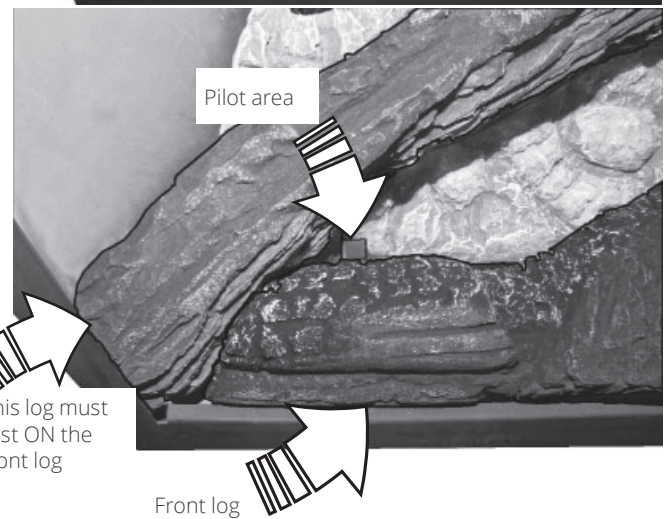

Installation

4. Place the front right log on the burner and slide it to the left against the front left log.

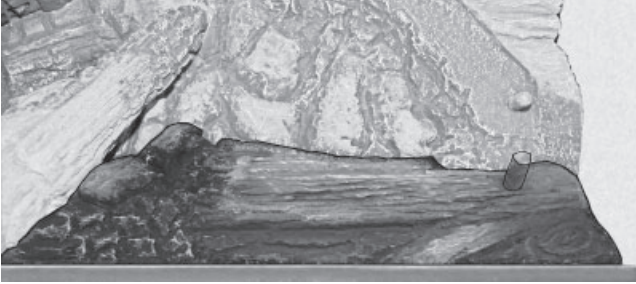

5. Locate the top right log on the two pins on the right side of the rear log. Ensure a tight fit against the flat area around the pins in the rear log.

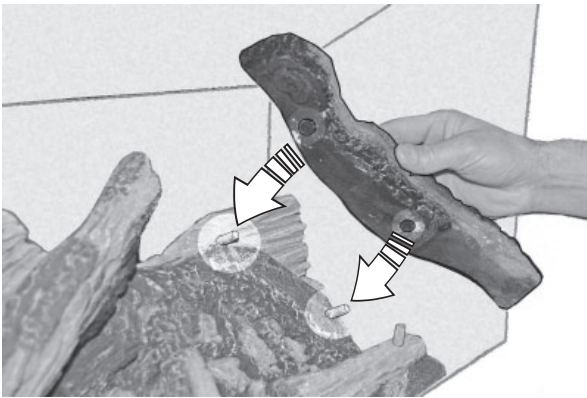

Install Fuel Bed

6. Place the lower end of the center right log onto the pin on the front right log. Rest the narrow in the notch into the rear log.

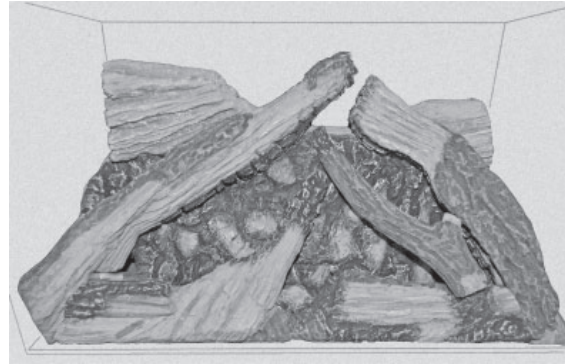
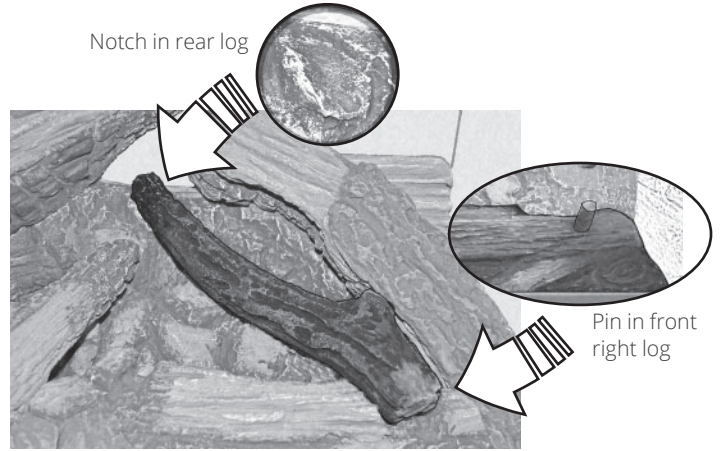

Installation

Driftwood Kit MF28DWK

Material required

- Driftwood Kit containing:
 - 1 ceramic platform
 - 5 logs
 - 6 pebbles
- Gloves, if desired (not included)

Installation

Unpack the ceramic logs very carefully to avoid damaging their fragile material. Install the logs as shown below. **Please note that the position of the logs is critical to ensure the good performance of the appliance.**

Platform

Insert the platform sideways into the firebox and place it on top of the burner.



Install Fuel Bed

Logs

1. Identify the base log and place it in the cavity of the ceramic platform. The protruding parts of the log in front should rest against the lip of the sheet metal log support behind the burner.

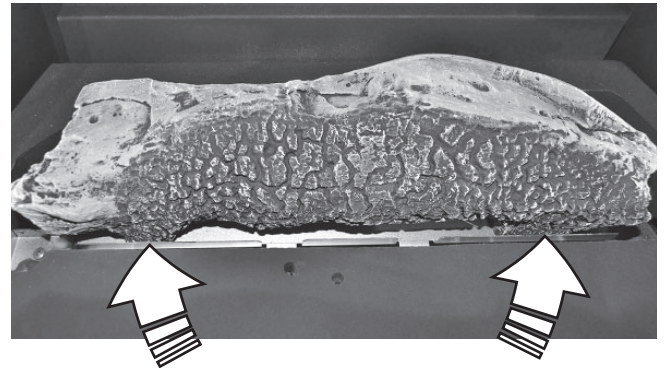

2. Identify the rear log and place it on top of the base log locating it into the notches on top of the log. Pull the log forward so it is locked in position.

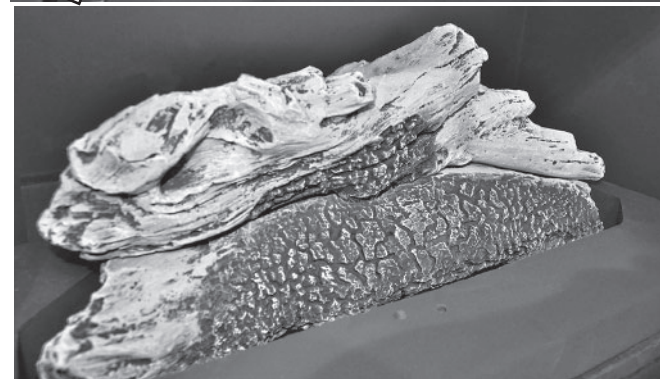
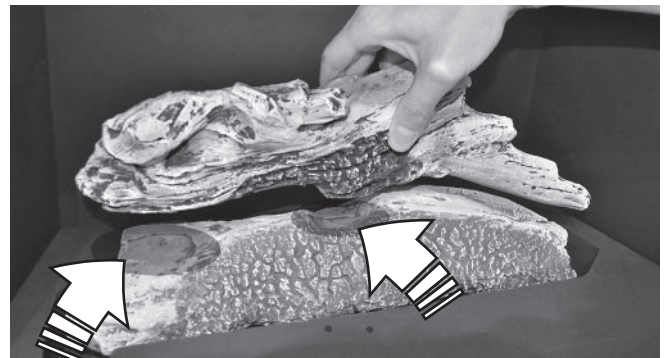

Installation

3. Identify the right side cross log, the longest, and place it across the rear log. The narrow end of the log rests in a notch of the rear log. The wide end of the log lays flat on the platform, flush with the edge as indicated.

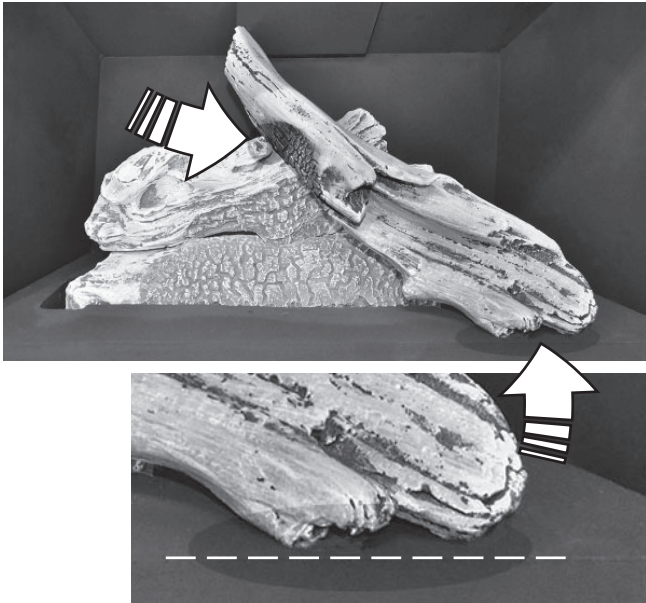

4. Identify the left side cross log which has one pin at one end. Insert the pin in the hole at the front left of the platform and rests the top part of the log into the notch of the rear log as indicated.



Install Fuel Bed

5. Place the front log inserting its two pins into the two holes at the front of the platform. The ends of the log should be oriented towards the front as the log should not hang over the inside edge of the platform.

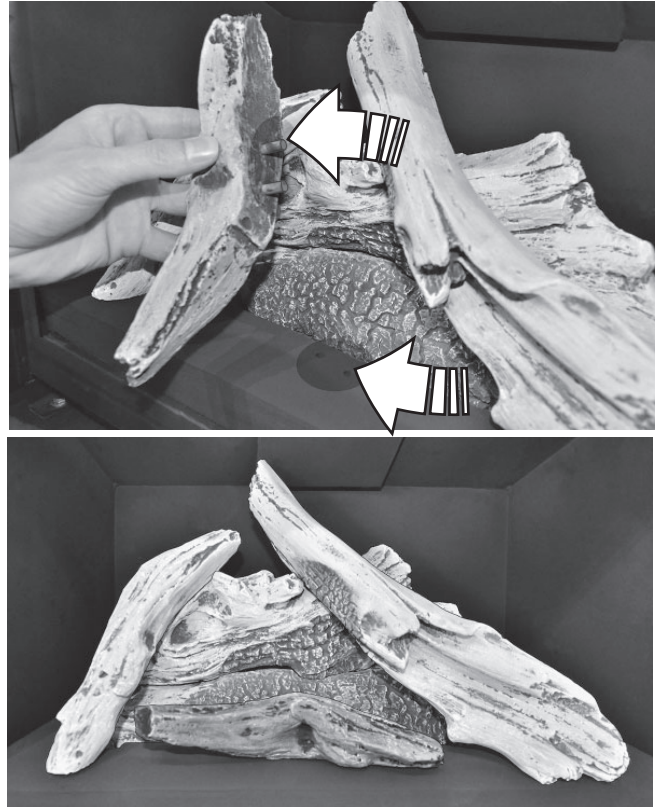

Pebbles

Six pebbles are supplied as decorative elements. If used, they should be placed on the platform only. We suggest to place the larger ones to cover the inside edge of the platform and place others randomly. Not all of them have to be used.

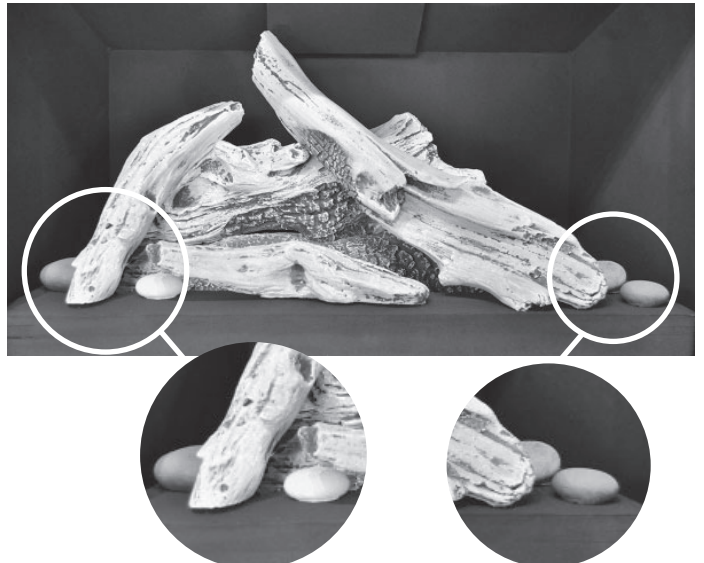

Installation

Refit & Check Window

Refit and Check Window

1. Hook the glass window to the firebox then fasten the four bolts pushing and turning them 90 degrees. Verify that each bolt is properly hooked by feeling with your fingers and ensuring the pin of the bolt is hooked to the fireplace's flange.

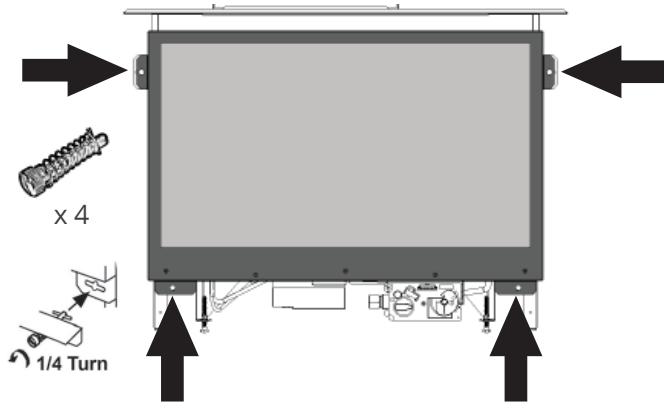

2. Pull out the window by the sides and release it to check that it opens slightly and returns confirming the good function of the spring-loaded mechanism.
3. Apply firm pressure around the window frame to ensure the window is sealed tight against the firebox.
4. If the Hot Glass Warning plate has been removed from the front lower corner of the window, re-install it by sliding it between the glass and the frame as indicated.

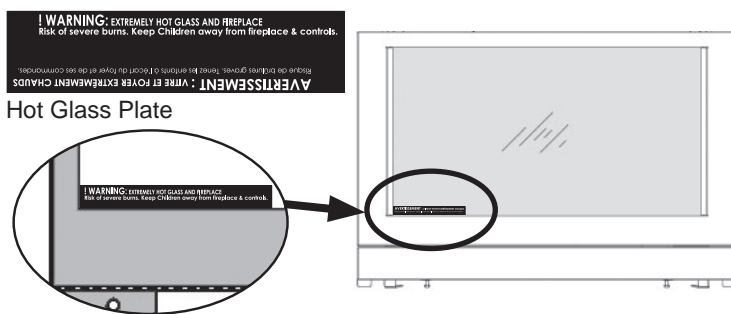

! WARNING

The window unit must be correctly installed, fastened and sealed after servicing or serious bodily injury and/or damage to the appliance may result.

To ensure a safe operation:

- Double-check that the window frame is correctly installed;
- Verify that the four bolts are hooked properly to the window tabs then;
- Pull out the sides of the window and release to ensure it returns to its position and the springs are working;
- Press all around the window frame against the firebox to ensure the window is well sealed before operation.

! WARNING

Failure to install the window correctly can:

- Leak carbon monoxide;
- Affect the performance of the fireplace;
- Damage components;
- Cause overheating resulting in dangerous conditions.

Damages caused by incorrect window installation is not covered by the Valor warranty.

Installation

Install Battery Holder

The batteries that power the receiver and handset need to be installed prior to pairing and use.

1. Take the receiver out from under the firebox.
2. Insert four 1.5 V high quality **alkaline** batteries in the battery holder supplied with the appliance and one high quality **alkaline** 9 V battery in the remote handset.



3. Connect the battery holder cable supplied with the appliance to the receiver as shown.

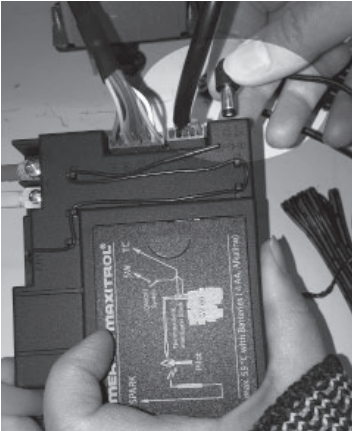

4. Connect the other end of the cable to the battery holder.

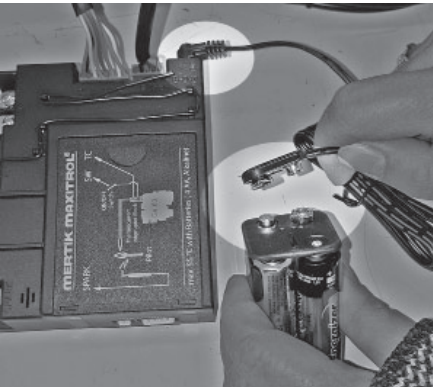

Install Battery Holder

5. Place the receiver and battery holder as shown under the firebox. Placement may vary with installed options.

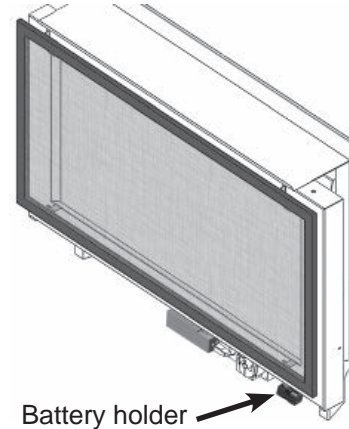

6. Use a heat-resistant tie to gather any extra cable between the receiver and the holder.

Caution

DO NOT let the cable touch the burner plate above, it will melt during operation.

Caution

Do not put batteries in the receiver as leaking acid could damage its circuit board.

Installation

Pair Remote Control

Synchronize Receiver and Handset

The receiver and handset of the remote control system must be initially paired before the first use.

1. If not already done, place a 9 V **alkaline** battery in the handset.
2. Identify the RESET button on the front of the receiver.
3. With a thin object, press and hold the receiver's reset button until you hear one short and one long beep. Release the button after the second beep.
4. Within the next 20 seconds, press the small flame button () on the handset until you hear two short beeps confirming the pairing is set.
If you hear a long beep, the pairing has not been done or the wires are not connected correctly.

This is a one time setting only and is not required when changing the batteries in the remote handset. The remote control system is now ready to use.

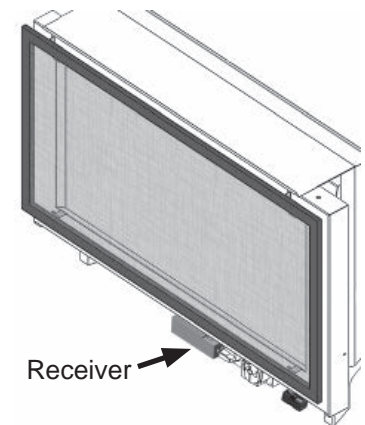
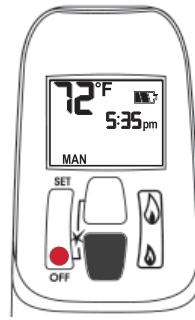

Installation

Check Operation

Turn the fireplace flame up and down using the remote control to confirm that the full range of inputs is achieved—see Appendix B – Remote Control Operation pages 44–47 for details.

Adjust Aeration (if needed)

Light the fire and allow the unit to warm up for 10–15 minutes to evaluate the flame picture. Burners are equipped with an adjustable shutter to control primary aeration. See figures below. The shutter is factory-set to an aeration gap which will give optimum performance for the vast majority of installations.

In some installations, depending of the fuel bed used, the altitude and other considerations, the flame picture may be improved by adjusting the aeration. The need for adjustment should be determined only by operating the appliance with the fuel bed and window installed and evaluating the flame picture after a 15-minute warm-up.

Check Burner Aeration

Increasing aeration (open) will cause the flames to appear more transparent and blue showing more ceramic effects glow.

Decreasing aeration (close) will cause flames to appear more yellow or orange showing less ceramic effects glow.

Too little aeration may result in black carbon forming on the logs or roof panel and dropping into the firebox. May also result in carbon or soot stains on the vent termination and exterior wall around the termination! The Manufacturer is not responsible for any damage caused by an air shutter setting with too little aeration.

Air Shutter

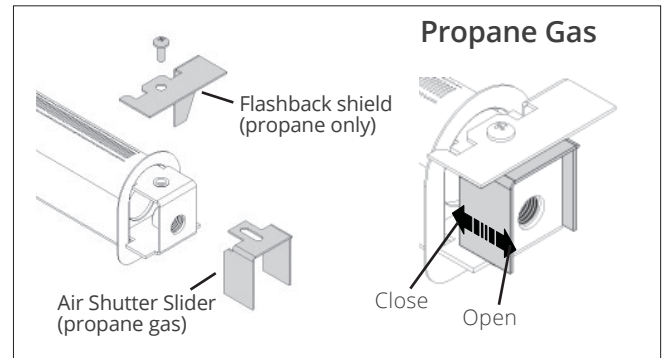
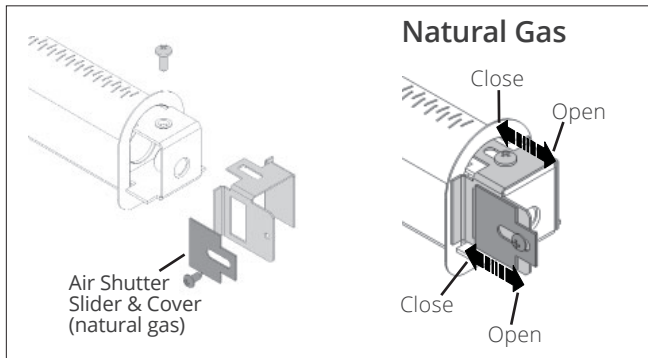

Installation

Barrier Screen/Window Cover/Vent Shield

Barrier Screen

A barrier screen is supplied with this appliance to install on the RetroFire window cover. The barrier screen is designed specifically to prevent any contact with the glass of the fireplace which becomes very hot during operation and remains hot when cooling.

It is easier to install the screen on the window cover first, before hooking the window cover to the fireplace.

1. Hook the top of the screen by inserting its tabs into the slots in the window cover.
2. Push the screen up and insert the lower tabs into the slots of the window cover. Pull the screen down to ensure the lower tabs are well inserted.

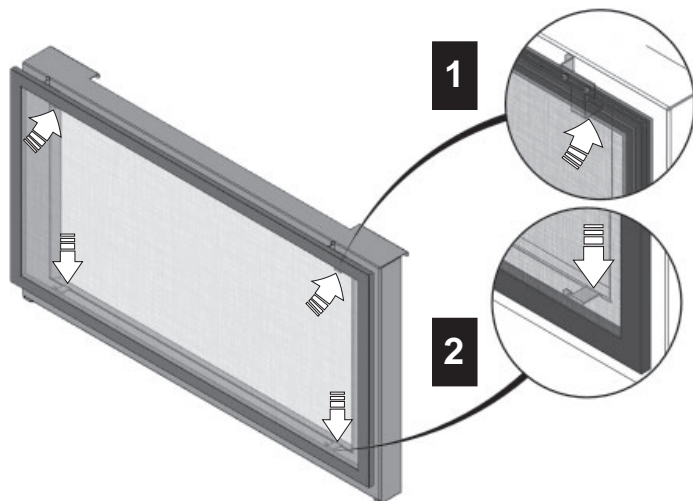

Window Cover

Hook the window cover with screen attached to the top of the firebox. Push the bottom against the firebox to attach the magnets.

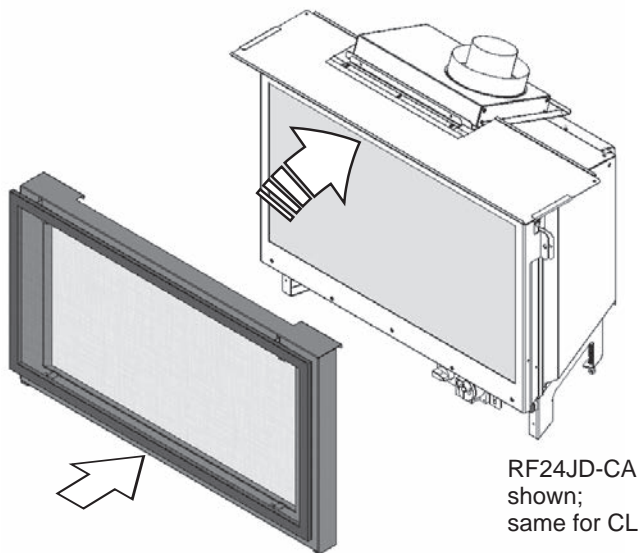

Top Vent Shield (if necessary)

The top vent shield is designed to install on top of the firebox in front of the vent plate to hide the vent plate and vent liners when visible.

Cut the top of the vent shield to size if necessary and place it in front of the vent plate as indicated.

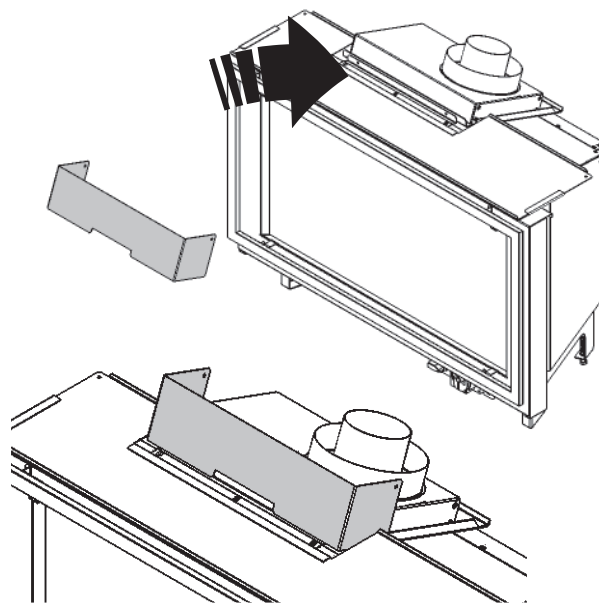

Appliance Identification

Data Plate

Pull out data plate from underneath appliance and mark clearly which appliance and vent plate are being used in this installation for future reference.

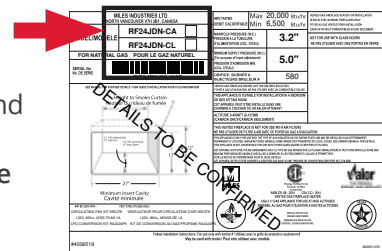

Front Cover of Installation Manual

Identify on the front cover of the installation manual which appliance and vent plate model are being used in this installation for future reference.



Installation

Bottom Cover / Fret

Install Bottom Cover or Cast Iron Fret

Bottom Cover Installation

IMPORTANT

When the bottom cover is used instead of a fret, a space is required in front of the barrier screen to allow the window to move and relieve during a hard start. It is therefore very important to ensure that an area of 3/4 inch (19 mm) in front of the barrier screen is kept clear at all times.

Slide the top flange of the bottom cover into slots located at the bottom corners of the window frame.

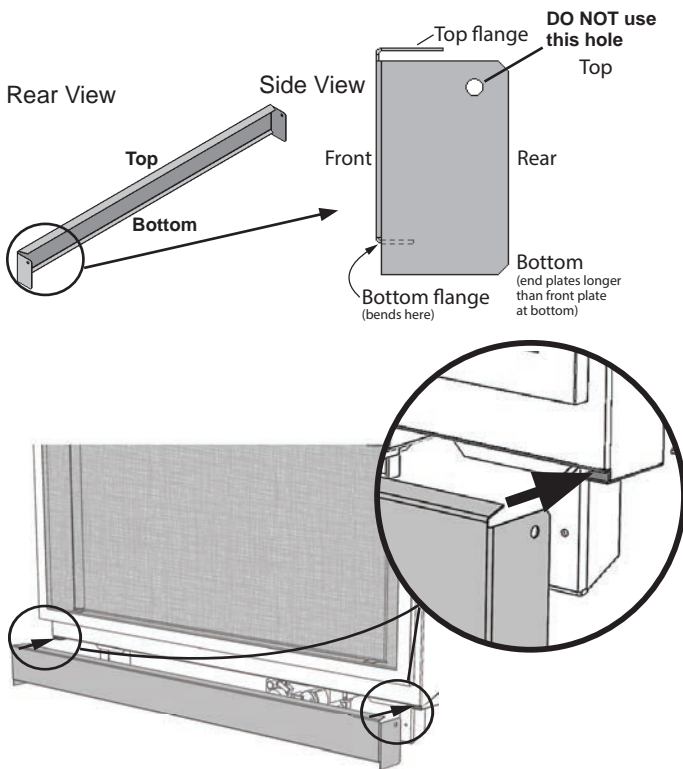

IMPORTANT

The fret retainer brackets are designed to maintain a space in front of the screen to allow the window to move and relieve during a hard start. It is very important to ensure this area in front of the barrier screen is kept clear at all times.

Fret Installation

Fret Brackets RF24FK Installation

1. Screw 2 thumbscrews into each retainer tab.
2. Fit the retainer tabs to each leg (1 screw per side).
3. Fit the slotted holes in the fret brackets over the thumbscrews, push the fret brackets downwards and tighten the screws.

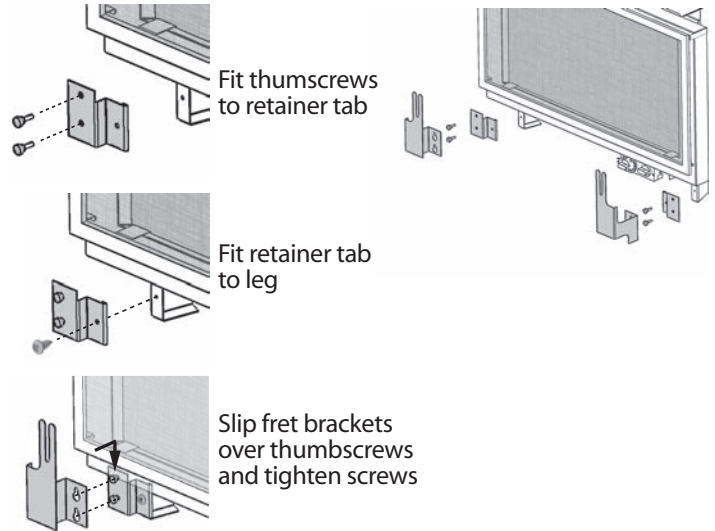

Cast Iron Fret Installation

1. Adjust the screw heads on the back of the fret to the thickness of the fret brackets.
2. Drop the fret into place while guiding the screw heads into the slots in the brackets.
3. Clip the ash pan cover onto the fret.

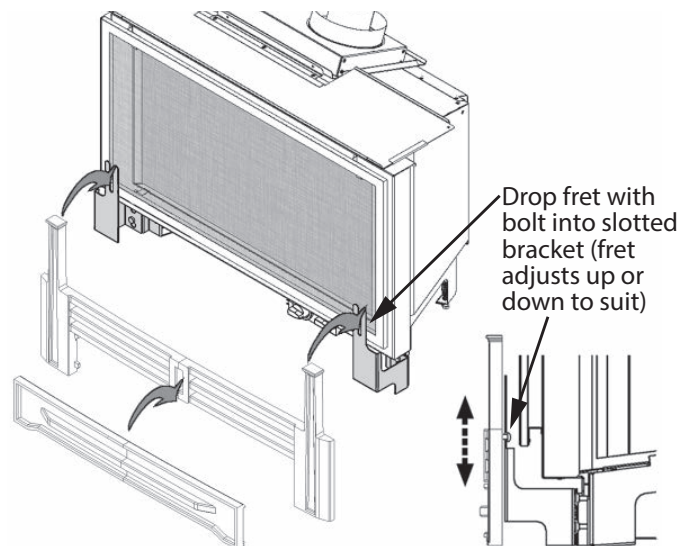

Installation

Install Handset Holder

Handset Wall Holder

The remote control kit for this fireplace comes complete with a wall-mounted holder. This holder is not required in all installations but is provided as an optional feature for those customers who wish to mount the remote handset to the wall.

To install the holder to the wall, find a convenient location and use the hardware provided with the kit. See the diagram below for required hardware and configurations. Note that the holder can be installed at the base of a light switch plate.

IMPORTANT. The location of the remote control handset is important to insure proper temperature regulation. To obtain a constant temperature, we recommend that the handset should be between 3 and 15 feet away from the appliance but not directly above it. We also advise that the handset should be located away from any other heat source and not in direct sunlight as this may affect the temperature sensor located in the remote handset.

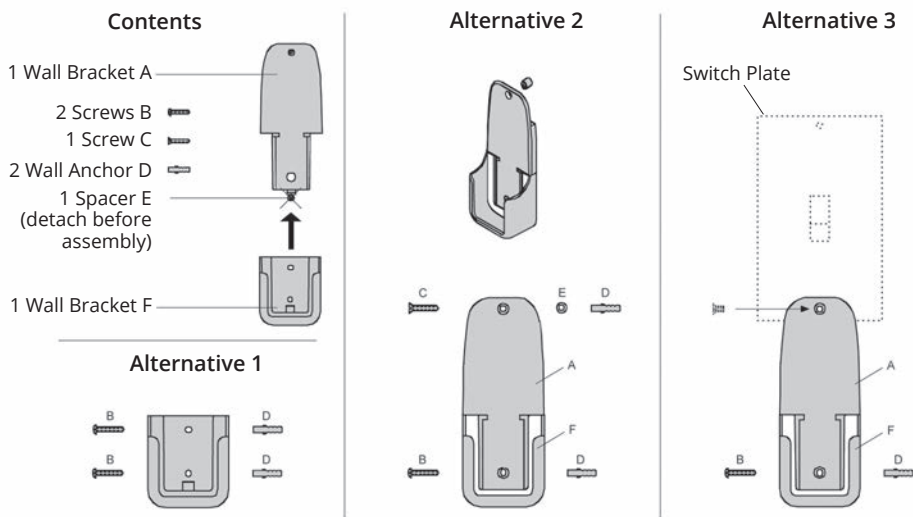

Wiring Diagram

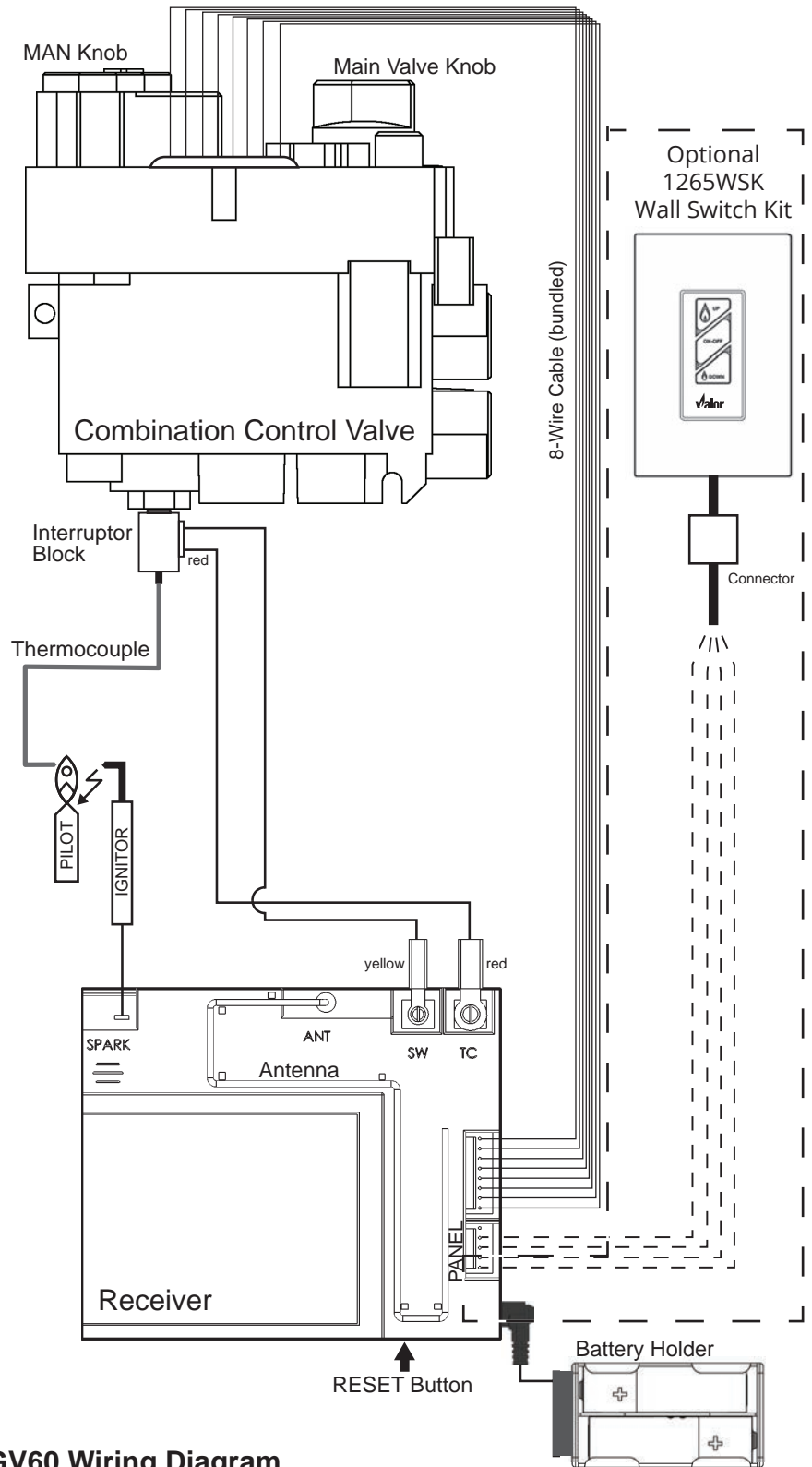

⚠ WARNING
NO ELECTRICAL CONNECTION
ALLOWED for any outdoor
installation!

GV60 Wiring Diagram

Commonwealth of Massachusetts

State of Massachusetts Carbon Monoxide Detector/Vent Terminal Signage Requirements

For all side wall horizontally vented gas fueled equipment installed in every dwelling, building or structure used in whole or in part for residential purposes, including those owned or operated by the Commonwealth and where the side wall exhaust vent termination is less than seven (7) feet above finished grade in the area of the venting, including but not limited to decks and porches, the following requirements shall be satisfied:

1. INSTALLATION OF CARBON MONOXIDE DETECTORS.

At the time of installation of the side wall horizontal vented gas fueled equipment, the installing plumber or gas fitter shall observe that a hard wired carbon monoxide detector with an alarm and battery back-up is installed on the floor level where the gas equipment is to be installed. In addition, the installing plumber or gas fitter shall observe that a battery operated or hard wired carbon monoxide detector with an alarm is installed on each additional level of the dwelling, building or structure served by the side wall horizontal vented gas fueled equipment. It shall be the responsibility of the property owner to secure the services of qualified licensed professionals for the installation of hard wired carbon monoxide detectors.

a. In the event that the side wall horizontally vented gas fueled equipment is installed in a crawl space or an attic, the hard wired carbon monoxide detector with alarm and battery back-up may be installed on the next adjacent floor level.

b. In the event that the requirements of this subdivision can not be met at the time of completion of installation, the owner shall have a period of thirty (30) days to comply with the above requirements; provided, however, that during said thirty (30) day period, a battery operated carbon monoxide detector with an alarm shall be installed.

2. APPROVED CARBON MONOXIDE DETECTORS. Each carbon monoxide detector as required in accordance with the above provisions shall comply with NFPA 720 and be ANSI/UL 2034 listed and IAS certified.

3. SIGNAGE. A metal or plastic identification plate shall be permanently mounted to the exterior of the building at a minimum height of eight (8) feet above grade directly in line with the exhaust vent terminal for the horizontally vented gas fueled heating appliance or equipment. The sign shall read, in print size no less than one-half (1/2) inch in size, "GAS VENT DIRECTLY BELOW. KEEP CLEAR OF ALL OBSTRUCTIONS".

4. INSPECTION. The state or local gas inspector of the side wall horizontally vented gas fueled equipment shall not approve the installation unless, upon inspection, the inspector observes carbon monoxide detectors and signage installed in accordance with the provisions of 248 CMR 5.08(2)(a)1 through 4.

(b) EXEMPTIONS: The following equipment is exempt from 248 CMR 5.08(2)(a)1 through 4:

1. The equipment listed in Chapter 10 entitled "Equipment Not Required To Be Vented" in the most current edition of NFPA 54 as adopted by the Board; and

2. Product Approved side wall horizontally vented gas fueled equipment installed in a room or structure separate from the dwelling, building or structure used in whole or in part for residential purposes.

(c) MANUFACTURER REQUIREMENTS - GAS EQUIPMENT VENTING SYSTEM PROVIDED. When the manufacturer of Product Approved side wall horizontally vented gas equipment provides a venting system design or venting system components with the equipment, the instructions provided by the manufacturer for installation of the equipment and the venting system shall include:

1. Detailed instructions for the installation of the venting system design or the venting system components; and

2. A complete parts list for the venting system design or venting system.

(d) MANUFACTURER REQUIREMENTS - GAS EQUIPMENT VENTING SYSTEM NOT PROVIDED. When the manufacturer of a Product Approved side wall horizontally vented gas fueled equipment does not provide the parts for venting the flue gases, but identifies "special venting systems", the following requirements shall be satisfied by the manufacturer:

1. The referenced "special venting system" instructions shall be included with the appliance or equipment installation instructions; and

2. The "special venting systems" shall be Product Approved by the Board, and the instructions for that system shall include a parts list and detailed installation instructions.

(e) A copy of all installation instructions for all Product Approved side wall horizontally vented gas fueled equipment, all venting instructions, all parts lists for venting instructions, and/or all venting design instructions shall remain with the appliance or equipment at the completion of the installation.

Appendix A – Lighting Instructions Plate

FOR YOUR SAFETY, READ BEFORE LIGHTING

WARNING: If you do not follow these instructions exactly a fire or explosion may result causing property damage, personal injury or loss of life.

A. This appliance has a pilot which must be lighted by hand or by remote control. Follow these instructions exactly. To save gas, turn the pilot off when not using the appliance for a prolonged period of time.

B. **BEFORE LIGHTING**, smell all around the appliance area for gas. Be sure to smell next to the floor because some gas are heavier than air and will settle on the floor.

WHAT TO DO IF YOU SMELL GAS

- Do not try to light any appliance.
- Do not touch any electric switch; do not use any phone in your building.
- Immediately call your gas supplier from a neighbor's phone. Follow the gas supplier's instructions.
- If you cannot reach your gas supplier, call the fire department.

C. Use only your hand to push in or turn the control knobs. Never use tools. If the knobs will not push in or turn by hand, don't try to repair them; call a qualified service technician. Force or attempted repair may result in a fire or explosion.

D. Do not use this appliance if any part has been under water. Immediately call a qualified service technician to inspect the appliance and to replace any part of the control system and any gas control, which has been under water.

LIGHTING INSTRUCTIONS

1. STOP! Read the safety information above

2. TO CLEAR ANY GAS, turn main valve off by pressing OFF (red dot) button on remote handset (1).

- Wait five (5) minutes to clear out any gas, then smell for gas, including near the floor. If you smell gas, STOP! Follow "B" in the safety information above on this label. If you don't smell gas, go to the next step.

3. **AUTOMATIC IGNITION:** MAN-knob (2) in ON position. Ensure Flame Adjustment knob (3) is set to lowest setting (U) (Fig. 1). Locate the pilot (Fig. 3) inside firebox.

- On the remote control handset, press the OFF button (red dot) and large flame button (🔥) simultaneously; a short acoustic signal confirms the start has begun.
- Further short acoustic signals indicate the ignition process is in progress.
- When the pilot is lit, the Flame Adjustment knob (3) will automatically rotate to the highest setting.
- Press the small flame button (🔥) on the remote.

4. **MANUAL IGNITION:** MAN-knob (2) in MAN position (Fig. 2).

With the window off, locate the pilot (Fig. 3) inside firebox.

- Set Flame Adjustment knob (3) to the lowest setting (U).
- Push down the metallic core (4) with a pin or similar instrument; this will establish the pilot gas flow.
- Light gas at the pilot (5) with a match.
- Continue holding down metal core (4) for about 10 seconds; after release, pilot should remain lit.
- If the pilot will not stay lit after several tries, turn the gas control knob (2) to OFF (U) and call your local service technician or gas supplier.
- Reinstall the window and set the MAN-knob (2) to ON; turn Flame Adjustment knob (3) up (U) or down (U) manually or use the flame buttons (🔥) (🔥) on the remote control handset to adjust the flame height.

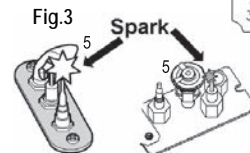
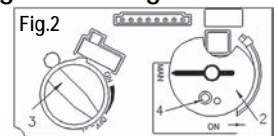
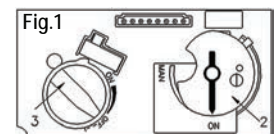
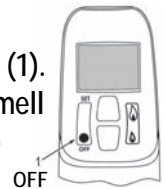

TO TURN OFF GAS TO APPLIANCE

1. **AUTOMATIC SHUT-OFF** (using the remote control handset):

- Press and hold the small flame on the remote control handset to shut-off the main burner gas flow;
- Press "OFF" button (red dot) on remote handset to shut-off the appliance, including pilot flame.

Appendix B – Remote Control Operation

Radio Frequency

315 MHz for USA and Canada.

This device complies with Part 15 of the FCC Rules and with Industry Canada license-exempt RSS standard(s). Operation is subject to the following two conditions:

- (1) this device may not cause harmful interference, and
- (2) this device must accept any interference received, including interference that may cause undesired operation.

NOTE: Before using the remote control system for the first time, the receiver and the handset must be synchronized. See *Pair Remote Control* on page 36 in this manual.

IMPORTANT: BEFORE YOU BEGIN, please note that on this system, the settings of time, temperature and automatic ON/OFF **can only be programmed when the function display is flashing.** Be patient when programming as it can take a few seconds to set.

Note: In the TEMP or TIMER modes, the remote handset senses the room temperature and adjusts the flame accordingly.

To communicate, the handset should be within 15 feet (4.5 meters) of the fireplace.

Do not leave the handset on the mantel or hearth.

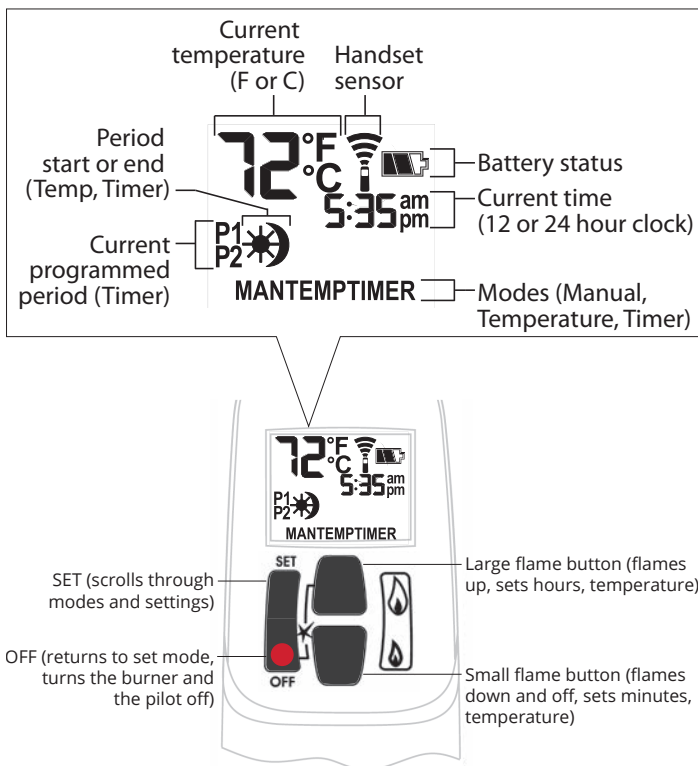

Turn Fireplace ON

Press ● + 🔥 buttons until you hear a short beep; release buttons.

Beeping continues until pilot is lit.

Burner lights to maximum flame height and handset goes automatically to manual (MAN) mode.

NOTES:

On the valve, MAN button must be at ON, in full counter-clockwise position ↺.

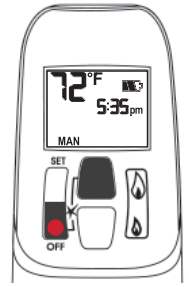

Turn Fireplace OFF

Press ● button.

When pilot is just turned off, wait 2 minutes to light it again.

Standby Mode (Pilot Flame)

Press and hold 🔥 to set fireplace to pilot.

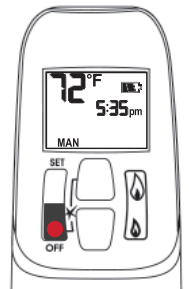

Adjust Flames Height

With pilot lit, press and hold buttons:

- 🔥 = increase flame height
- 🔥 = decrease flame height or set to pilot

For fine adjustment, tap buttons.

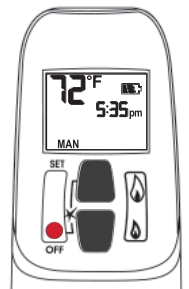

Express Low and High Fire

Double-click buttons:

- 🔥 = increase flame to maximum height "HI"
- 🔥 = decrease flame minimum height "LO"

NOTE: Flame goes to high fire first before going to designated low fire.

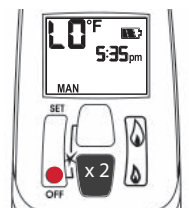
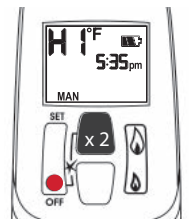

Appendix B – Remote Control Operation

Setting °C/24-hr or °F/12-hr clock

In MAN mode, press and hold ● + 🔥 buttons until temperature / clock display changes from

°F / 12-hour ↔ °C / 24-hour

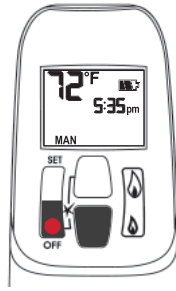

MAN Manual Mode

Manual flame height adjustment.



☀️ TEMP Daytime Temperature Mode

When pilot is lit, room temperature is measured and compared to set temperature. Flame height automatically adjusts to reach Daytime Set Temperature.

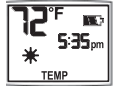

Setting Time

The time display will flash after either:

- installing the battery, or
- pressing 🔥 + 🔥

To set the time, press buttons:

🔥 = hour

🔥 = minutes

Press ● briefly or wait to go back to MAN.

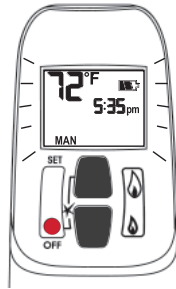

🌙 TEMP Night time Setback Temperature Mode

When pilot is lit, room temperature is measured and compared to set temperature. Flame height automatically adjusts to reach Night Time Setback Temperature.

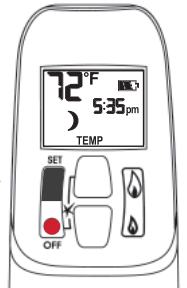

TIMER Timer Mode

When pilot is lit, two periods of time (P1 and P2) can be programmed to use Daytime and Night time temperatures at specific times.

Note: Display shows set temperature every 30 seconds.



Modes of Operation

Briefly pressing SET cycles through modes of operation.

MAN > ☀️ TEMP > 🌙 TEMP > TIMER > MAN

NOTE: Press 🔥 or 🔥 to reach MAN mode.

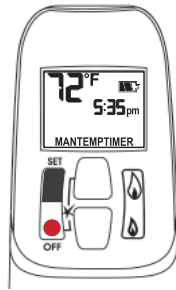

Set the different parameters when they are flashing.

Appendix B – Remote Control Operation

Setting high / low Temperatures

Setting “DAYTIME” high temperature.

Default Settings: TEMP 23 °C/74 °F

Press SET to scroll to TEMP

Hold SET button until TEMP flashes.

To set Daytime Temperature:

= increases temperature.

= decreases temperature.

Press briefly or wait to complete setting.

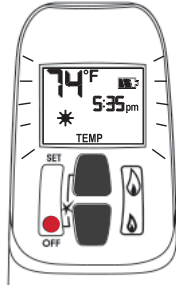

Setting “NIGHT TIME SETBACK” low temperature.

Default Settings: TEMP “--” (OFF)

Press SET to scroll to TEMP

Hold SET button until TEMP flashes.

To set Night Time Temperature:

= increases temperature.

= decreases temperature.

Press briefly or wait to complete setting.

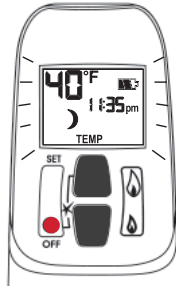

Setting Program Timers

You can program two periods of time between 12 am and 11:50 pm in each 24-hour cycle.

Programs P1 and P2 must be set in the following order during a 24-hour cycle: **P1** , **P1** , **P2** and **P2** .

= Day Time temperature (high) program period

= Night Time temperature (low) program period

Default Settings:

Program 1: **P1** 06:00 am **P1** 08:00 am

Program 2: **P2** 11:50 pm **P2** 11:50 pm

Press SET to scroll to .



If **P1** = **P1** or **P2** = **P2** , programming is cancelled.

To keep fireplace ON all night, set **P2** at 11:50 am and **P1** at 12:00 am.

If you want to program only one period, program **P1** and **P1** with desired times then **P2** and **P2** with the same time as **P1** .

Setting P1 time—high temperature.

Hold SET button until **P1** is displayed and time flashes.

To set time:

= hour

= minutes

Press briefly or wait to complete setting.

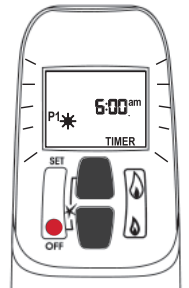

Setting P1 time—low temperature.

Hold SET button until **P1** is displayed and time flashes.

To set time:

= hour

= minutes

Press briefly or wait to complete setting.

Appendix B – Remote Control Operation

Setting P2 high and low temperature times.

Repeat same steps as Setting P1.

When all settings are complete, press ● to save them.



The pilot has to be lit for the system to respond to the program Temp or Timer settings.

Timer Programming Example (default temperatures shown)

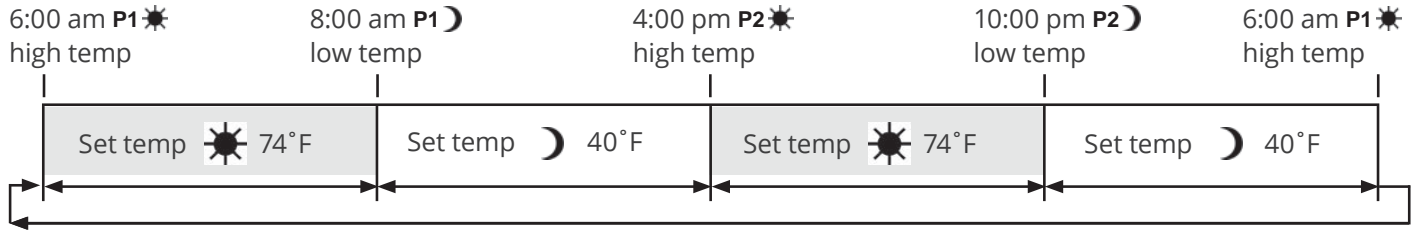

Automatic Turn Down

8-Hour no Motor Movement

The valve will turn to pilot flame if there is no motor movement for an 8-hour period.

Automatic Shut-Off

Low Batteries Receiver. With low battery power in the battery holder the system shuts off the fire completely. This does not apply when the power supply is interrupted.

On-Demand Pilot (7 Day Shut-Off). This green feature eliminates gas energy consumption during extended appliance inactivity. When the appliance is inactive for an extended period of time the system automatically extinguishes the pilot. This feature helps the consumer realize cost benefits by automatically eliminating energy consumption during non-heating months and limited use.

The programmed length of inactivity to activate the system is specified by the appliance manufacturer and cannot be altered in the field.

Low Battery Indication



Caution

DO NOT USE a screwdriver or other metallic object to remove batteries from holder. This could cause a short-circuit.

Handset: The battery icon  will show when the battery needs to be replaced. Replace with one 9 V **alkaline** battery.

Battery holder: Frequent 'beeps' for 3 seconds when the valve motor turns indicate the batteries need to be replaced in battery holder. Replace with four 1.5 V **alkaline** batteries.

Handset / Receiver Match

The remote control handset and receiver are programmed to function together. In case of a replacement of the handset or the receiver, you will need to reset the receiver to allow them to function together. Contact your dealer for details.

Appendix C – Spare Parts

	Description	Part No.
1	Co-Axial Vent Plate	RA24CA
2	Co-Linear Vent Plate	RA24CL
3	Exhaust Gasket	4001662
4	Leg LH	4003884
5	Leveling Bolt (2)	4000242
6	Leg RH	4003885
7	Rear Log Support	4001890
8	Small Convection Baffle	4006417BY
9	Convection Baffle Extension	4006418BY
10	Vent Shield	4006428AZ
11	Window Assembly	4006518
12	Window Cover	4006407BY
13	Barrier Screen	4006519
14	Bottom Cover	4002835
15	Hot Glass Warning Plate	4003093
16	Burner Tray Assy (natural gas)	4006506S
	Burner Tray Assy (propane gas)	4006507S
17	Burner (natural gas)	740K189
	Burner (propane gas)	740K190
18	Air Shutter Cover (natural gas)	4002346
19	Flashback Shield (propane gas)	3000371
20	Air Shutter Slider (natural gas)	4002345
21	Air Shutter Slider (propane gas)	320B293
22	Injector Elbow 82-580 (natural gas)	720A580
	Injector Elbow 92-260 (propane gas)	9730007
23	Spacer Angles (2)	4000355
24	Burner Mounts (2)	4000132
25	Pilot Assembly (natural gas)	4007220S
	Pilot Assembly (propane gas)	4007221S
26	Pilot Bracket	720A542
27	Pilot Injector—No 35 (natural gas)	4002511
	Pilot Injector—No 27 (propane gas)	720A195
28	Hooked Olive for Pilot Injector	720A196
29	Olive Nut—Pilot Pipe to Pilot Assembly	420K385
30	Electrode	4001856
31	Electrode Retaining Nut	4001855
32	Thermocouple	4000061
33	Pilot Shield	4000144
34	Pilot Gasket	4000139
35	Pilot Mount	4000138
36	Pilot Mount Gasket	4000140

	Description	Part No.
37	Pipe—Valve to Main Burner (incl. olive & nuts)	4000065
38	Valve Tray	4001627
39	Rear Gasket	4000642
40	RH Side Gasket	4000643
41	Front Gasket	4000641
42	LH Side Gasket	4000644
43	Break-off Olive Nut—Pilot Pipe to Valve	220K913
44	Pipe—Valve to Pilot	4000066
45	Inlet Connector	220K997
46	Inlet Pipe	030A224
47	Valve Mounting Bracket	4000141
49	Thermocurrent Interruptor	4001037
50	GV60 Valve, without connectors	4000873
50a	Inlet connector	4000746
50b	Straight connector	220K891
50c	By-pass screw #125 (natural gas)	incl. with #50
	By-pass screw #125 (propane gas)	incl. with #50
51	Receiver PLUS	4001911
51a	Battery holder	4006553
51b	Battery holder cable 1500 mm	4006552
52	Wiring Harness	4001187
53	Ignition Cable	4001039
54	Ignition Cable Sleeve	4002244
55	Cable Interruptor/Receiver	4001035
56	Cable Interruptor, yellow	4002096
57	Handset PLUS	4001910
58	Handset Wall Holder	9000008
59	Fret Kit	RA24FK
60	Fret Support LH	4003652BY
61	Retainer Tab LH	4003650
62	Fret Support RH	4003651BY
63	Retainer Tab RH	4003649
64	Thumbscrew # 10-32x1/2" (4)	4000753
65	GV60 Valve Repair Kit	4004544
66	Traditional Log Set	MF28LSK
67	Rear Log	4003803
68	Left Top Log	4003796
69	Right Top Log	4003797
70	Right Center Log	4003798
71	Left Front Log	4003800
72	Right Front Log	4003801
73	Driftwood Kit	MF28DWK
74	Rear Log	4005384

Appendix C – Spare Parts

	Description	Part No.
75	Base Log	4005383
76	RH Cross Log	4005381
77	Front Log	4005382
78	LH Cross Log	4005380
79	Small Beige Beach Pebble (3)	4003087
80	Small Grey Beach Pebble	4003086
81	Brown Beach Pebble	4003082
82	Grey Beach Pebble	4003083
83	Platform	4005385

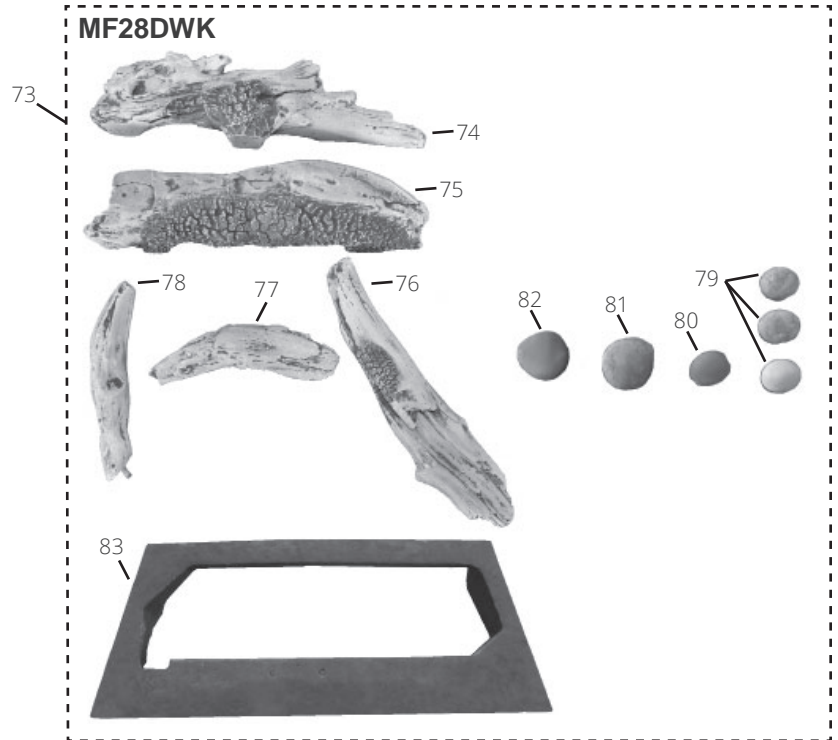
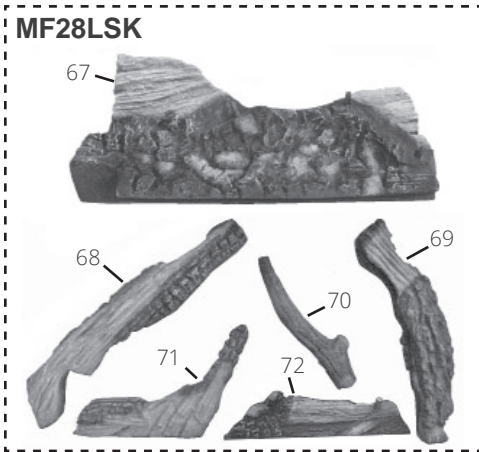

Appendix C – Spare Parts

